

**DRUM LIQUID LEVEL GAUGE
KIDNEY LOOP & BREATHER
ASSEMBLY INSTRUCTIONS**

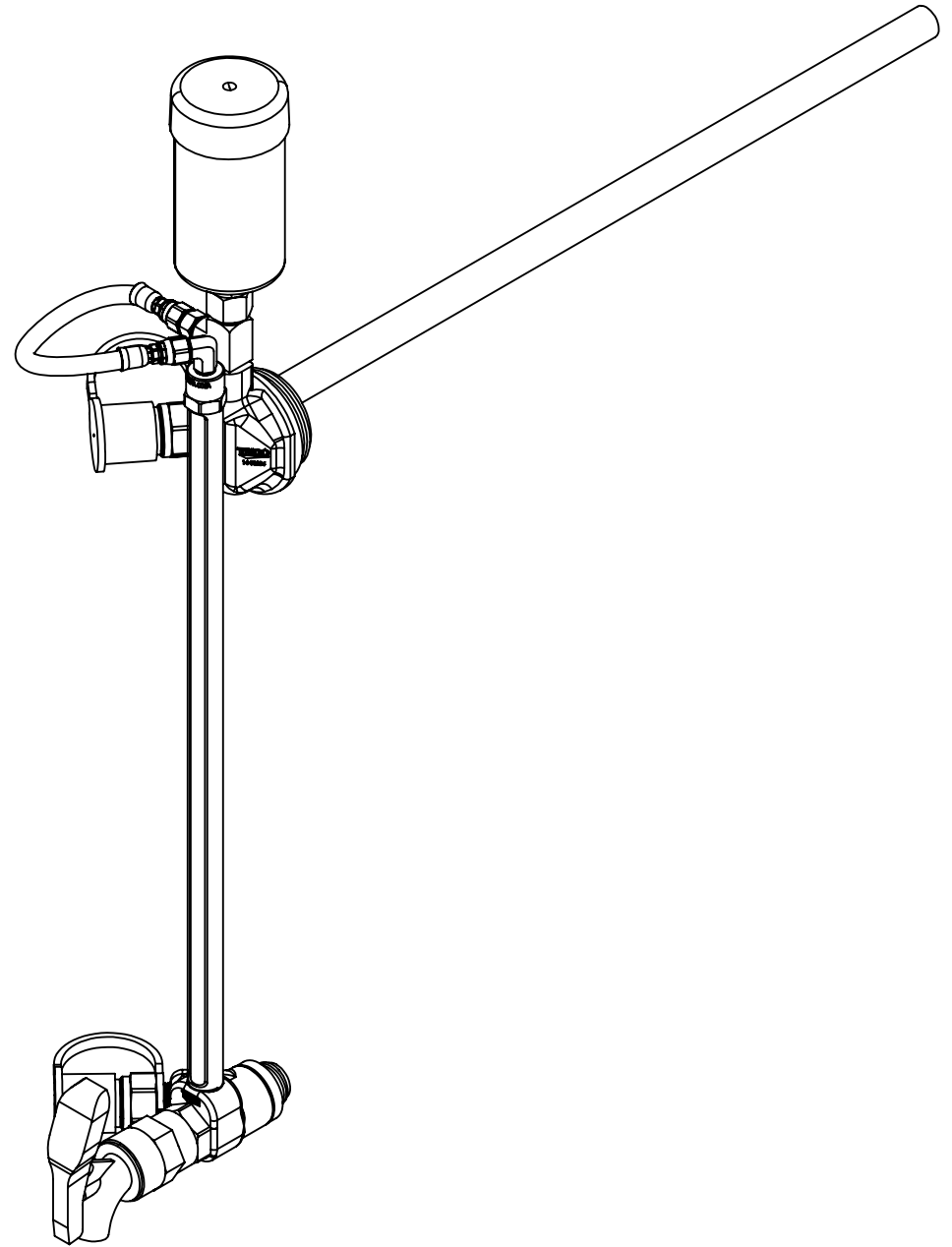
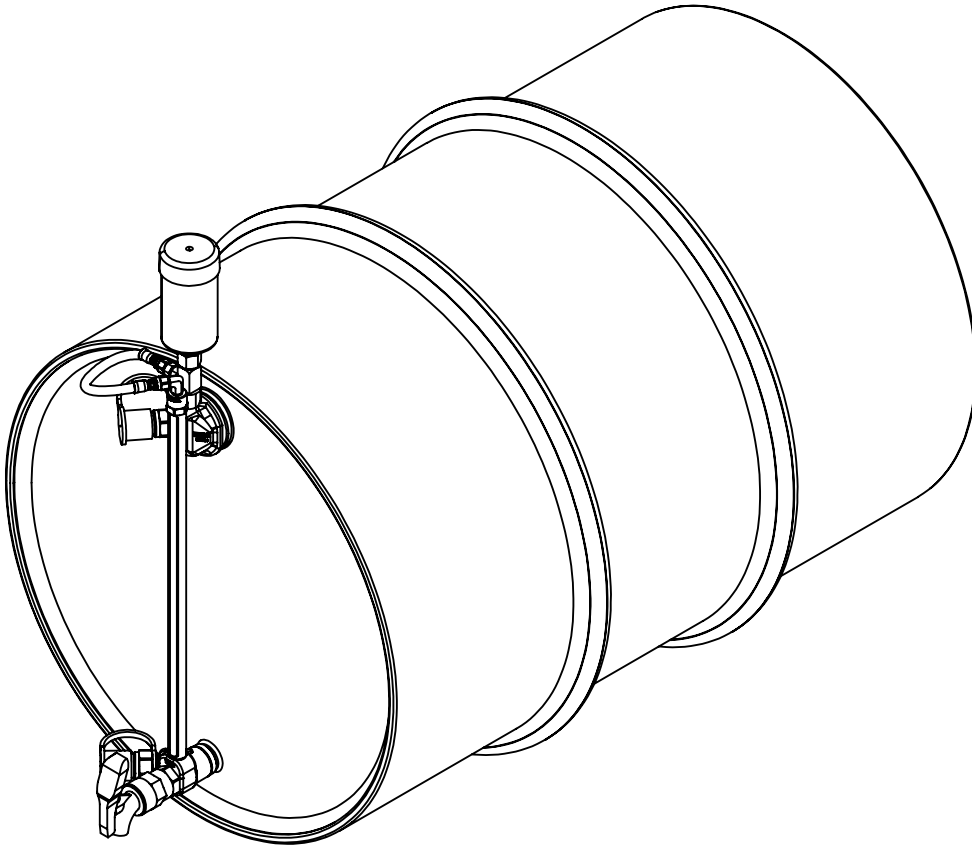

61259
Rev 2 2/1/2024

**COVER
SHEET**

1 OF 6

**DRUM LIQUID LEVEL GAUGE
KIDNEY LOOP & BREATHER
ASSEMBLY INSTRUCTIONS**

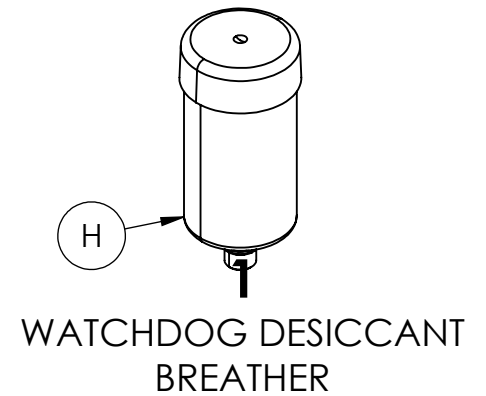
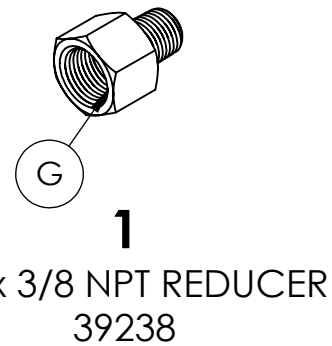
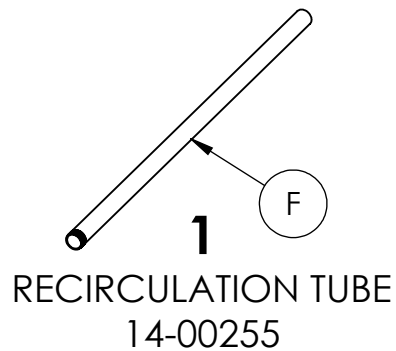
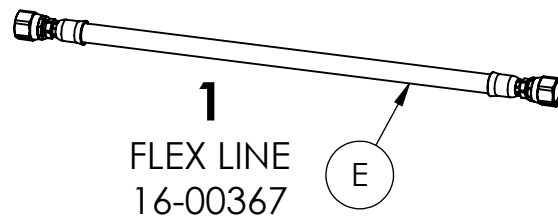
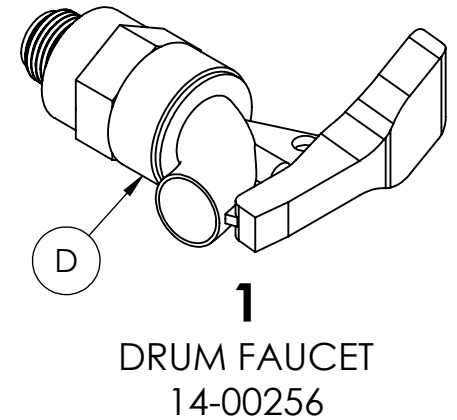
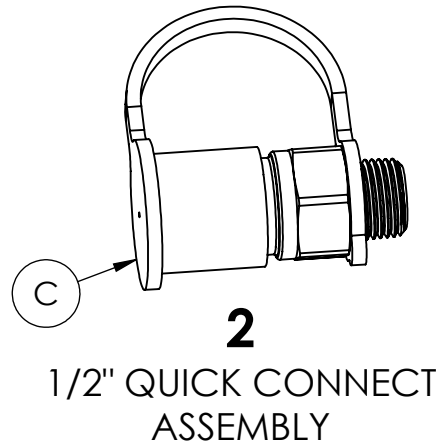
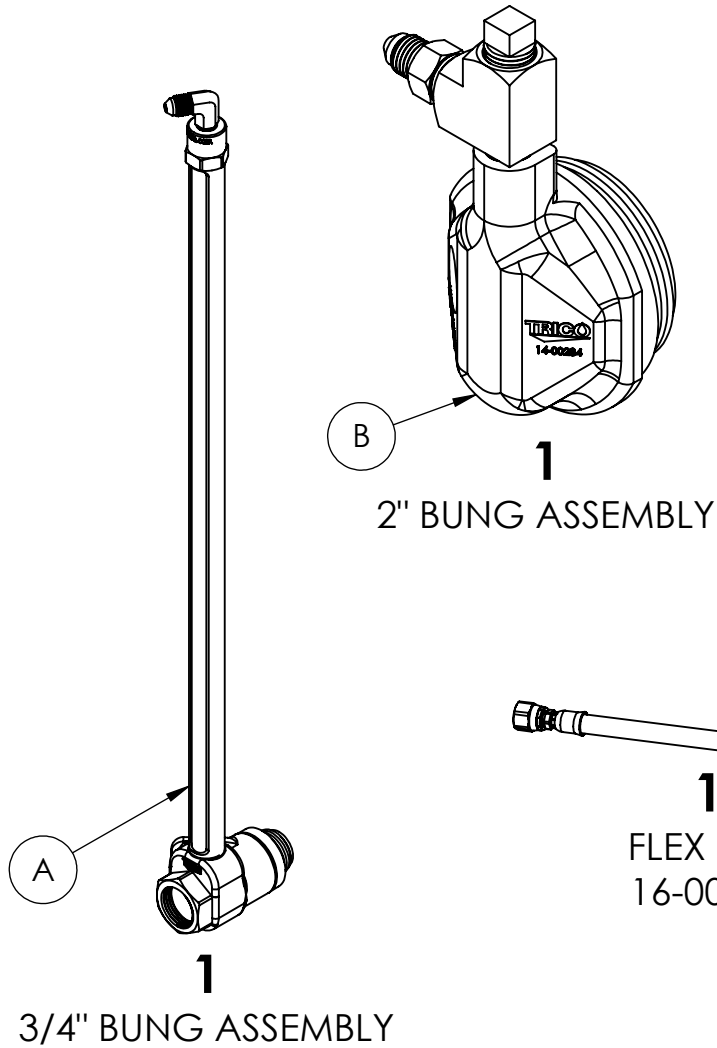

DRUM LIQUID LEVEL GAUGE KIDNEY LOOP & BREATHER ASSEMBLY INSTRUCTIONS

STEP 1

1. Remove both 2" and 3/4" Bungs from Drum
2. Screw 3/4" Bung Assembly (A) into the 3/4" Bung hole on Drum making sure the assembly is tight onto the drum compressing the gasket and lining up with the 2" Bung

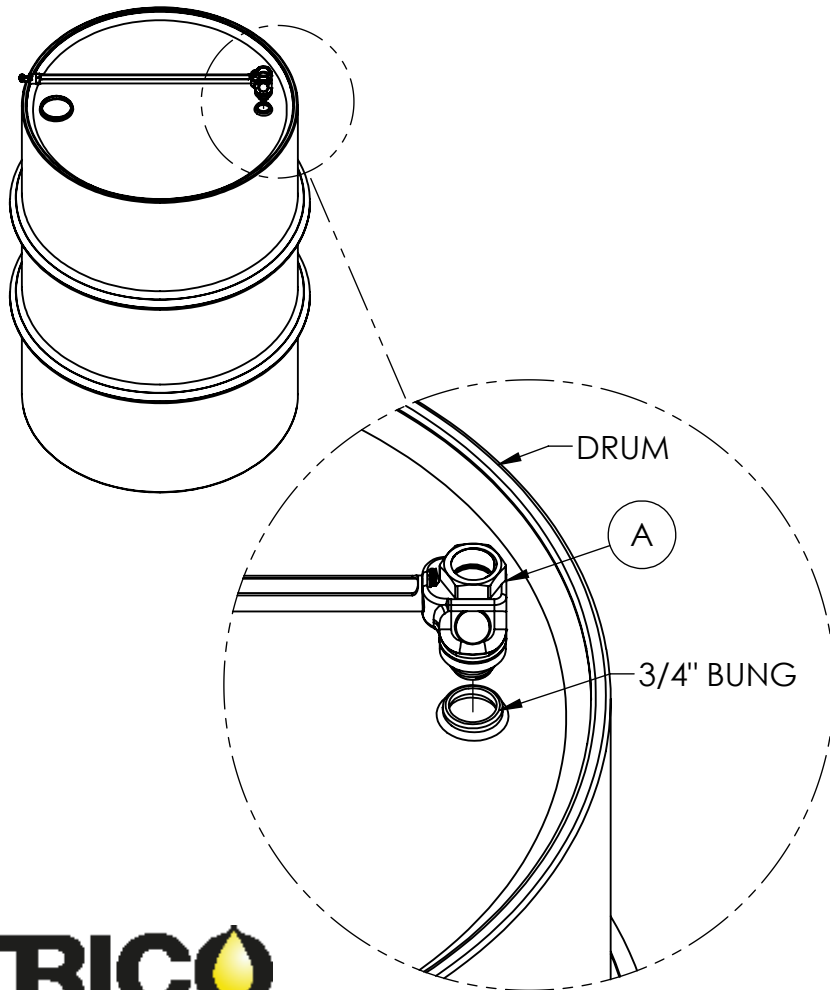

STEP 2

1. Using thread sealant, attach Drum Faucet (D) to 3/4" Bung Assembly (A)

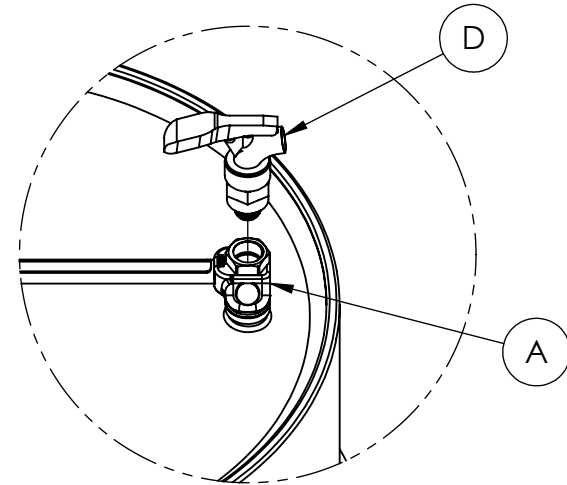

STEP 3

1. Using thread sealant, attach Recirculation Tube (F) to 2" Bung Assembly (B) prior to inserting into Drum

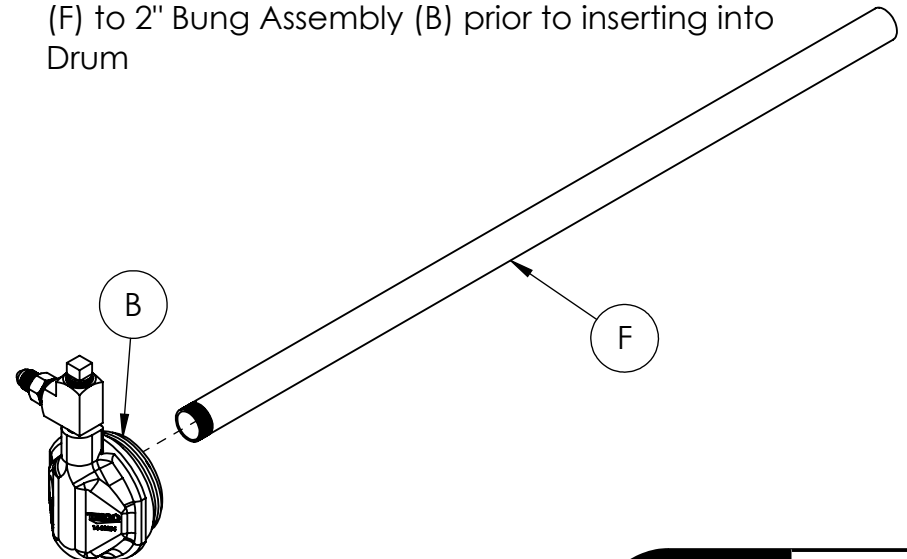

DRUM LIQUID LEVEL GAUGE KIDNEY LOOP & BREATHER ASSEMBLY INSTRUCTIONS

STEP 4

1. Screw 2" Bung Assembly (B) into the 2" Bung hole on Drum making sure the assembly is tight onto the drum compressing the gasket and lining up with the liquid level gauge (A)

Note: You may need to turn the Liquid Level Gauge (A) away from the 2" Bung Hole for easier assembly (Part A not shown below)

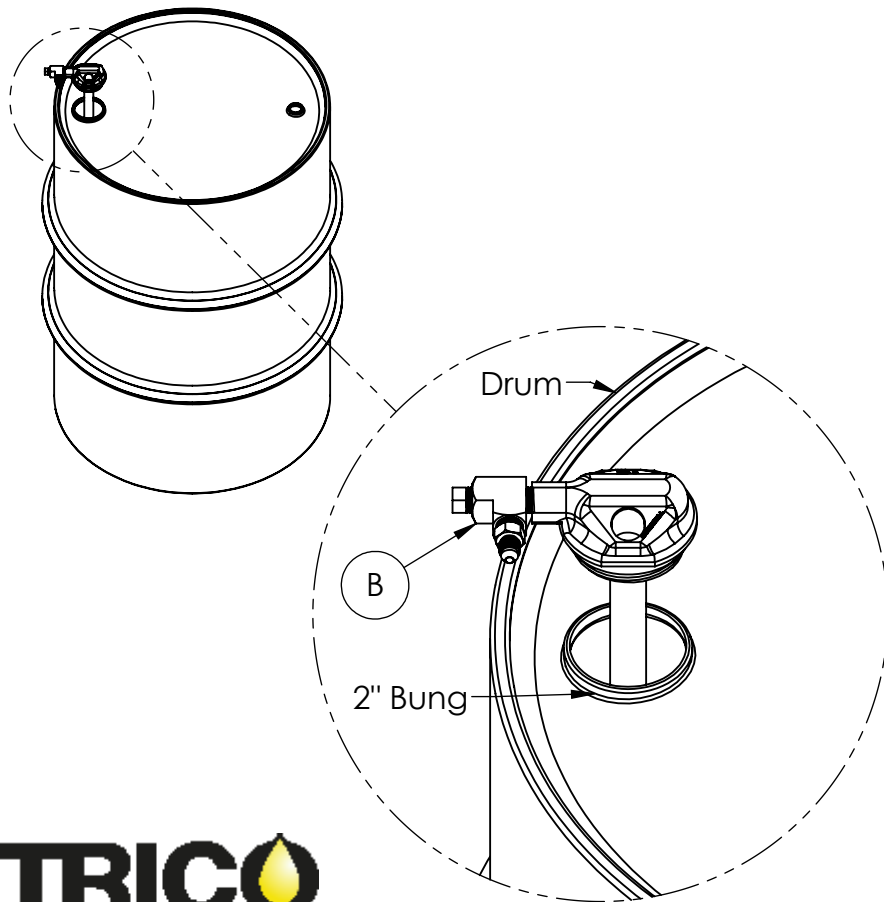

STEP 5

1. Using thread sealant, connect 1/2" Quick Connect Assemblies (C) to both 3/4" Bung Assembly (A) and 2" Bung Assembly (B)

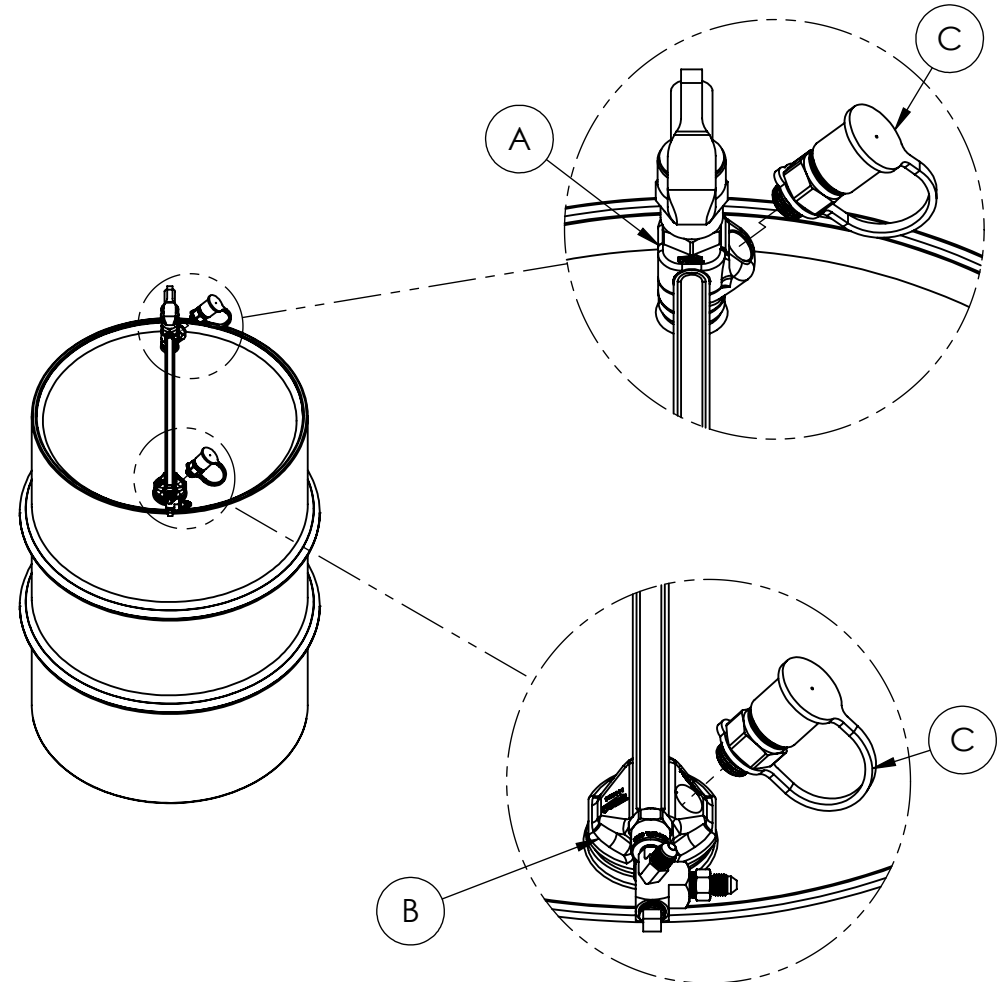

DRUM LIQUID LEVEL GAUGE KIDNEY LOOP & BREATHER ASSEMBLY INSTRUCTIONS

STEP 6

1. Connect Flex Line (E) to both JIC fittings on the 3/4" Bung Assembly (A) and 2" Bung Assembly (B)
2. Make sure 1/4" Plug is tight on top of the 2" Bung Assembly (B) and then flip the drum horizontally into storage location with the 3/4" Bung Assembly (A) facing towards the spill containment area

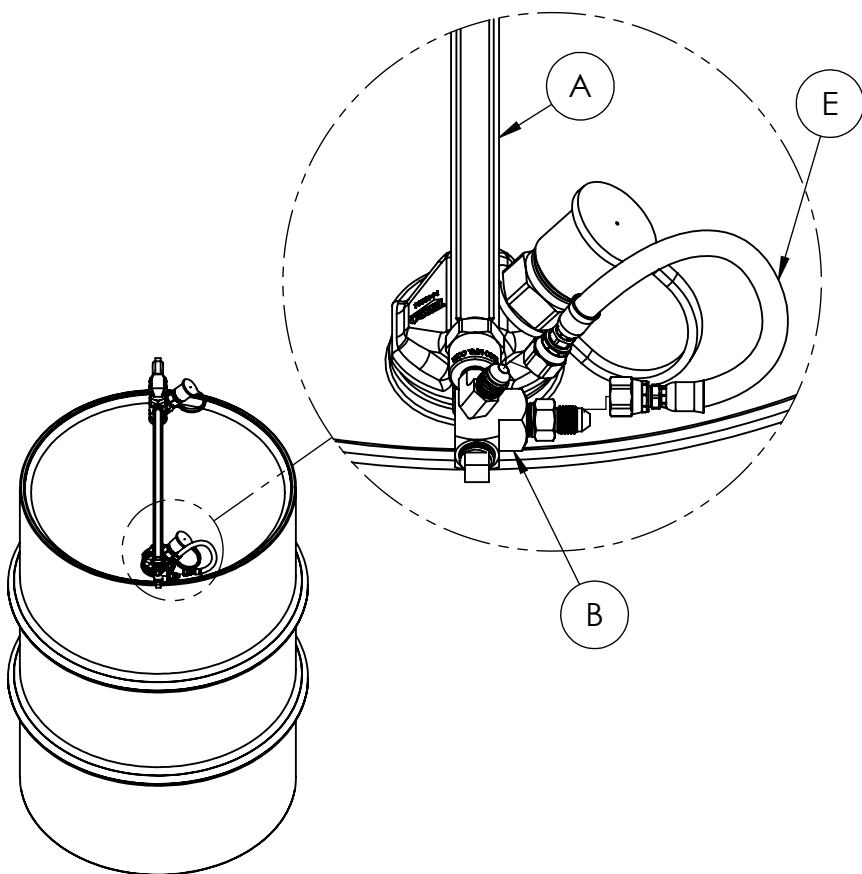

STEP 7

1. Remove 1/4" Plug on top of the 2" Bung Assembly (B)
2. Using thread sealant, connect Reducer (G) to 2" Bung Assembly (B)
3. Screw Watchdog Breather (H) onto Reducer (G)
DO NOT USE SEALANT

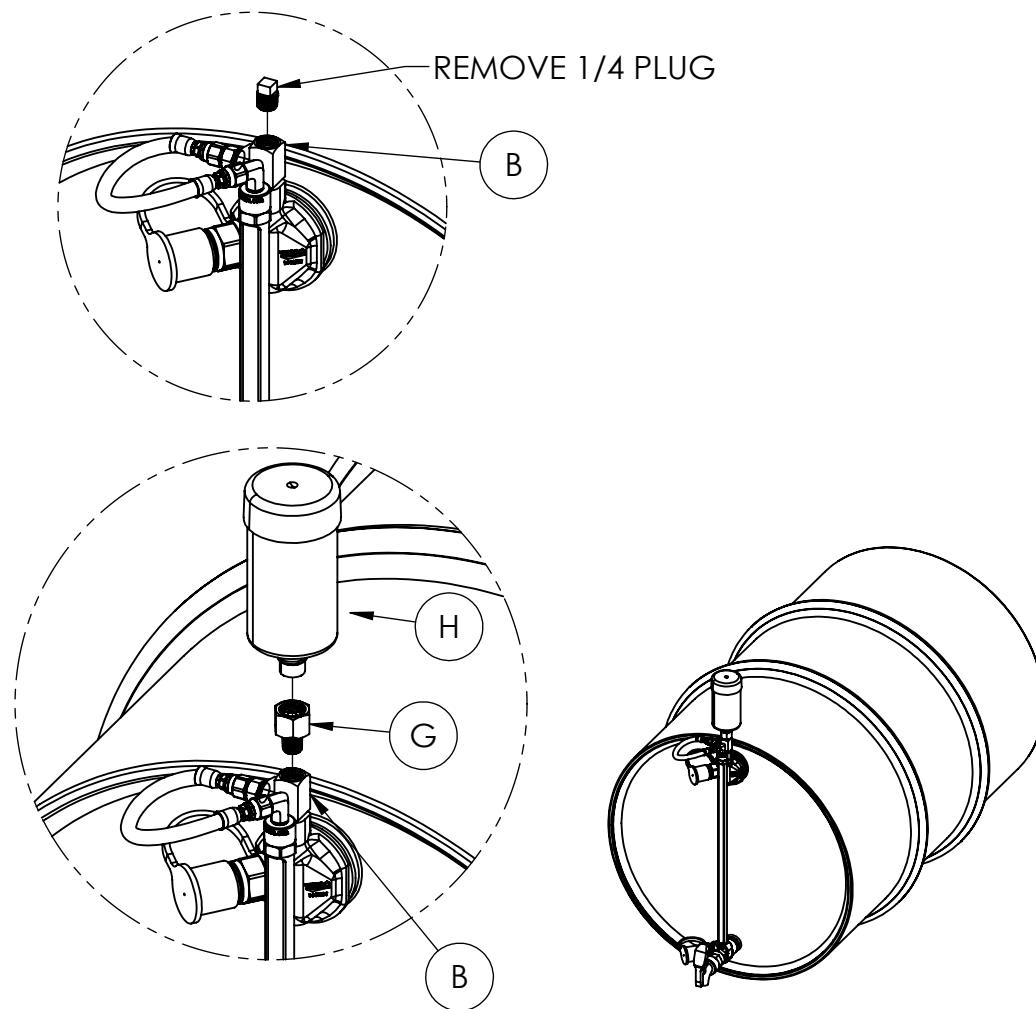

DRUM LIQUID LEVEL GAUGE KIDNEY LOOP & BREATHER SPECIFICATIONS

ALL DIMENSIONS SHOWN IN INCHES

