



SprayMaster II

Read Instructions Before Installing

- **DO** supply clean, dry air to the SprayMaster II. A coalescing filter is mandatory if an air line lubricator is used upstream.
- **DO** use only water based coolants designed for spray cooling in the SprayMaster II.
- **DO NOT** spray toxic or volatile liquids in the SprayMaster II.

To Install:

1. Mount the reservoir in any convenient location slightly below the level where the nozzles will be mounted. The nozzles must be kept above the level of the reservoir to prevent siphoning. Drill two holes eight inches on center and thread with a 5/16-18 tap. Mount the unit using the slotted head screws provided. The unit may also be mounted using the optional magnet mounting kit P/N 30687.
2. Connect a source of clean, dry shop air (50 - 100 psi) to the female 1/4" NPT fitting on the left side of the cover.
3. Remove the filler cap and fill the reservoir with a water soluble coolant mixture designed for mist spraying.
4. Mount nozzles with brackets provided. The nozzles may also be mounted using the optional mounting magnets P/N 30460 or 30630.
5. Position nozzles approximately one inch from the cutting tool.
6. Plug the unit into a 110/120 V - 50/60 Hz. grounded receptacle.

To Operate:

This unit is designed with individual control of air and coolant. This provides a wide range of mist "wetness" and cooling capability. Adjust the air and coolant to deliver spray to the tool contact point, wet enough to create a slight beading of moisture on the work piece. Coolant evaporating at the tool contact point provides the desired cooling effect.

1. Turn unit on with main on/off switch. The indicator light in the switch will illuminate when the unit is operating.
2. Open the liquid and air controls one full turn.
3. When air and coolant mixture appears from the nozzle, adjust the air and coolant flow to the desired levels.

NOTE: Improved cooling and coolant delivery is obtained when larger droplets are utilized. Avoid an excessively dry mist.

To Clean:

1. Always unplug or disconnect the electric power supply before cleaning the system.
 2. Do not submerge the unit in any liquid.
 3. To clean the reservoir interior, remove the screw at each end and tilt the cover back carefully to avoid damage to electrical and air/coolant connections. Locate and remove the two screws that hold the solenoid mounting bracket in place and lift the solenoid assembly and cover from the reservoir. Wash the reservoir with warm, soapy water or Trico Cleaner that will not harm the Buna-N grommets and o-rings, polyethylene tank, or the acrylic sight tube. The same solution can be run through the system to clean the lines and nozzles. Never use solvents, as they will damage the seals, grommets, or sight tube.
 4. Clean the filter pick-up screen.
 5. Inspect, clean and dry all electrical connections and reassemble.
-

Control Valve Replacement:

1. Unthread the knurled cap and slide the armored line away from the valve body 2-3 inches (50-75 mm).
 2. Use needle-nose pliers to pull the retainer eyelet away from the valve body and cut the air and coolant tubes lengthwise over the small barbs. Pull the tubes from the valve. Leave the retainer eyelet on the air tube. Do not allow the tubes to slip into the armored line.
 3. Cut the minimum required to clean-up the end of each tube.
 4. Take the new control valve and push the air tube (with eyelet) completely over the barb closest to the black needle valve. Slide the eyelet up over the barb to the valve body. Push the coolant tube completely over the other barb.
 5. Slide the armored line to the valve body and thread the knurled cap.
-

Nozzle Replacement:

1. Unscrew nut at base of nozzle assembly.
 2. Pull nozzle assembly out of control valve.
 3. Insert new nozzle into block.
 4. Tighten nut at base of assembly.
-

Line Replacement:

1. Remove the old line assembly by loosening the knurled ferrule at the nozzle end. Slide the armored line away from the nozzle and cut the clear and the blue tubes.
2. Separate the cover assembly and reservoir by removing the small screw at each end of the unit. From inside the cover, locate and cut the clear and the blue tubes from the air and coolant valves. Remove the nut and lock washer that retain the armored line. Remove the line and discard it.
3. Feed the clear and the blue tubes of the new line assembly through the hole in the cover, insert the press fitting into the hole, and replace the lock washer and nut.
4. Push the clear tube completely onto the brass tube of the coolant valve. Be sure the retainer (flanged end out) is slipped over the clear tube. Push the tube completely over the barb on the air valve and slide the retainer up to the valve body. Reassemble the cover and reservoir.
5. Trim the remaining tubing from the nozzle and reassemble using the control valve replacement instructions above.

Optional Remote Signal:

The SprayMaster II is equipped with provisions for remote signaling of the unit from a PLC, CNC control, limit switch, etc. Power is still provided by the power cord, but is switched through a remote switch or set of contacts. The switch provided with the unit will still be operational when using this option, allowing manual operation if desired. Standard 115V versions are equipped with three 4.5 W solenoids. Two power wires and a ground are left available in the unit. They are equipped with 1/4" female spade connectors.

1. Remove the top cover by removing the fill cap and two screws on the ends of the unit.
2. Remove the hole plug next to the power cord in the cover.
3. Route wires from the remote switch through the hole in the housing using an appropriate strain relief.
4. Locate the two power wires and ground wire in the housing. They are red, black, and green.
5. Connect the power leads to the remote switch contacts, and the ground wire to the ground on the switch if equipped.
6. Test for proper operation and reassemble unit.

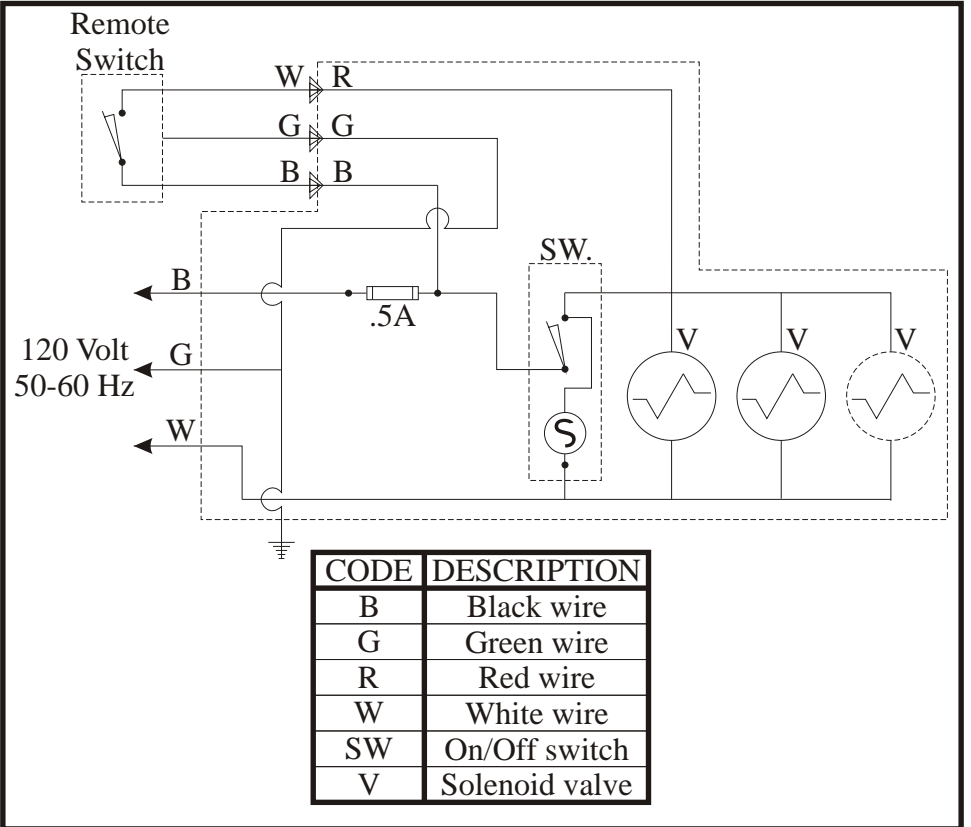

Replacement Parts:

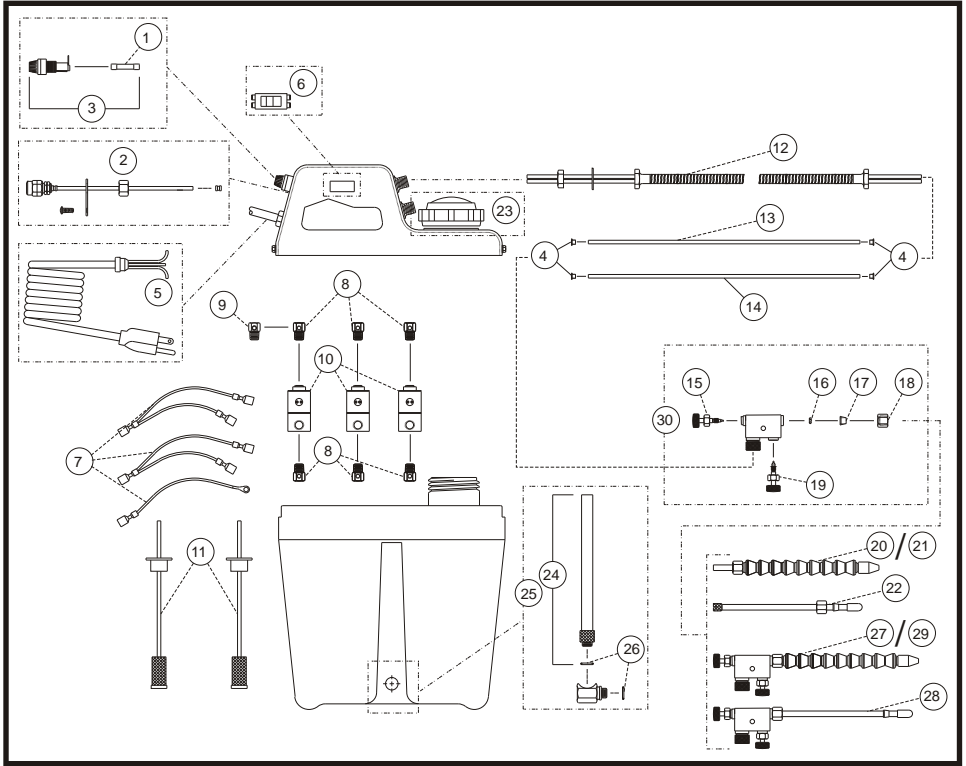

Item #	Part #	Description	Item #	Part #	Description
1	11547R	Fuse - .5 amp	16	11276R	1/8 ID o-ring
2	21186R	Air inlet & bracket	17	11275R	1/4 OD tube sleeve
3	11548R	Fuse holder w/fuse	18	11274R	1/4 OD tube nut
4	11871R	Retainer eyelet	19	21193R	Air needle
5	21143R	6' cord set w/restraint	20	30622	7" locline nozzle
6	11546R	On/off switch	21	30623	12" locline nozzle
7	21339R	Wire harness kit	22	30260	6" straight nozzle
8	11681R	Elbow fitting	23	11530R	Cap
9	12070R	4-way tee fitting	24	21132R	Sight tube & o-ring
10	11537R	Solenoid	25	21185R	Level indicator
11	21398R	Filter assembly	26	18671R	7/16 ID o-ring
12	21134R	5' armored line assm.	27	30449	Control valve w/30622
13	66223R	5/32 OD clear tubing	28	30447	Control valve w/30260
14	66247R	5/32 OD blue tubing	29	30450	Control valve w/30623
15	20699R	Liquid needle	30	21375R	Control valve