



Automatic Cyclic Pumps PE-20, PE-22, and PE-24 Series

Read Instructions Before Installing

To Install:

1. Obtain all available information from the system designer. This may include bill of materials, lubrication point locations, etc..
2. Mount the reservoir in the desired location. It should be:
 - A. Visible to the operator.
 - B. Easy to re-fill and service.
3. Mounting hole dimensions and clearances are shown on the inside of this instruction sheet.
4. Electrical Connections - consult a qualified electrician.
 - A. Always follow local electrical codes, safety regulations and procedures when installing an electrical system.
 - B. Wire the pump to the switched side of the machine disconnect so the two are energize simultaneously.
 - C. Wire per schematic on the inside of this instruction sheet.
5. Interval Adjustment PE-20 and PE-22 Series
 - A. Using black knob, located on the front panel of the unit, set interval time to zero.
 - B. Turn power on to verify oil is being discharged from the outlet. Oil will be discharged at a cycle time of ten seconds.
 - C. After oil has been discharged from the unit, turn unit off and connect pump to system.
 - D. Turn unit on and verify oil is being discharged from each lubricating point.
 - E. Using black knob, adjust interval time to system requirements.
6. Interval Adjustment PE-24 Series
 - A. Using black knob, located on the front panel of the unit, set interval time to zero. Set second knob, lubricating time, to ten seconds.
 - B. Turn power on to verify oil is being discharged from the outlet. Oil will be discharged at a cycle time of thirty seconds, when interval time is set to zero.
 - C. After oil has been discharged from the unit, turn unit off and connect pump to system.
 - D. Turn unit on and verify oil is being discharged from each lubricating point.
 - E. Adjust interval and lubricating time to system requirements
7. Pumps equipped with a low level switch. When the switch is activated it will shut down the motor to avoid damage to the pump.
8. Pumps equipped with a low level alarm. When the low level switch is activated the alarm will sound.
9. General installation practice is to mount the meter units at each lubrication point and interconnect them with tubing. Always point arrow on meter unit in direction of flow. Follow your system schematic. When connecting pipe threads apply a small amount of thread sealant to the external thread. If at all possible, the most distant lubrication point should be piped in an upward position from pump.
10. Piping is done with metal or plastic tubing. Take care to prevent dirt or contamination from entering into the piping. You may choose to leave a final fitting (near the meter unit) slightly loose to facilitate the initial bleeding of air and checking of oil delivery to each point. Failure to observe oil at a point requires tracing the system back towards the pump in search of a kink in a line, a loose fitting, or other problems.
11. Always use clean oil poured from a clean container. Do not mix oil types or change viscosity without consulting your machine manufacturer.
12. Clean the reservoir and filter elements periodically as dictated by the oil cleanliness. If in doubt, check for cleanliness at 3 months, and then 6 months. Determine service frequency based on what is found.
13. If contamination enters the system, disconnect lines and flush them out. Empty reservoir, clean filter elements and re-fill the system with clean lubricant.



Automatic Cyclic Pumps PE-20, PE-22, and PE-24 Series

Read Instructions Before Installing

Wiring:

1. Remove the cover over the connectors (fig. 1). Make sure the pump is facing the same direction as in the illustration and rotate to the right 90°.

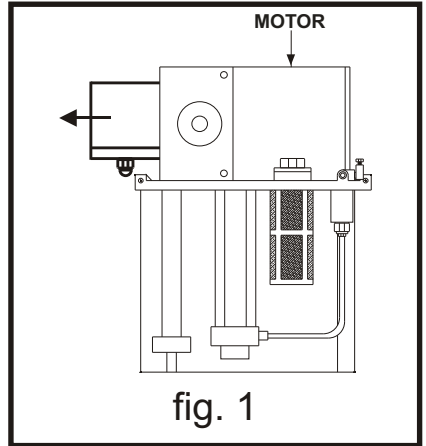

2. Wire per schematic (fig. 2).

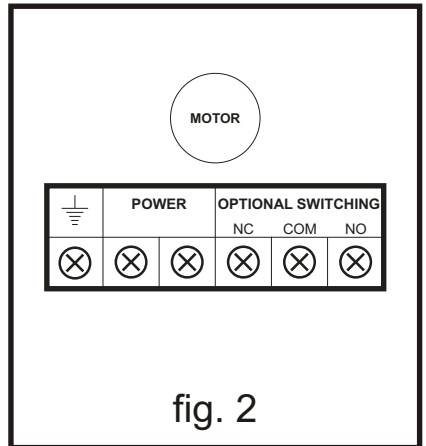



Automatic Cyclic Pumps PE-20, PE-22, and PE-24 Series

Read Instructions Before Installing

Dimensions: Dimensions in mm

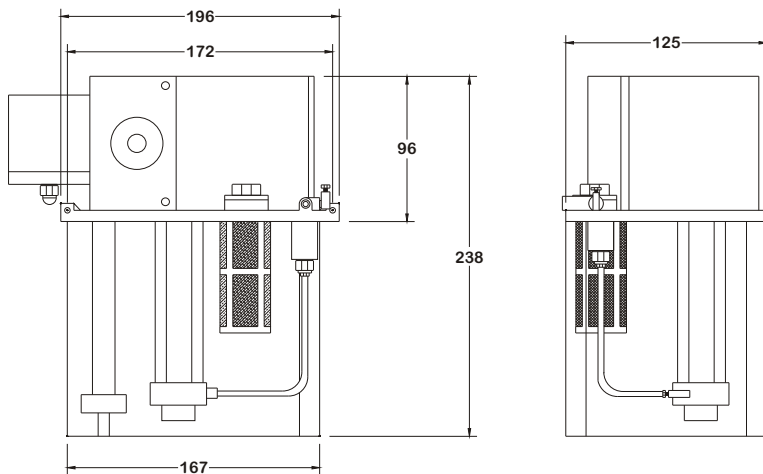

Specifications:

Reservoir Capacity	2 liters
Motor Voltage	110v 50/60 standard 220v 50/60 optional
Pump Type	Gear pump
Maximum Pressure	70 psi
Output Connection	5/16-24 (f)

Selection Chart:

Model No.	Output	Interval Time Between Cycle	Minimum Output cc/hour	Low Level Switch	Low Level Alarm and Pressure Gauge
PE-2002-06	6 cc/cycle	10 sec. to 60 min.	6*	Yes	No
PE-2002-15	15 cc/cycle		15*		
PE-2202-06	6 cc/cycle		6*		Yes
PE-2202-15	15 cc/cycle		15*		
PE-2402	3.33 cc/sec. Variable delivery time of 0-180 sec.	30 sec-180 min	1.1		Yes

*Factory set. Not adjustable