

Selection Chart:

Model No.	Reservoir Capacity (liters)	Reservoir Material	Output	Interval Time between Cycles	Minimum Output (cc/hr)	Level Switch
PE-3003	3	Plastic	3.33 cc/sec. Variable delivery time of 1-180 sec.	3-999 min.	.2	Yes
PE-3006	6	Metal				
PE-3008	8					
PE-3020	20					
PE-3203	3	Plastic	4.17 cc/sec. Variable delivery time of 1-999 sec.	3-999 min.	.2	Yes
PE-3206	6	Metal				
PE-3208	8					
PE-3220	20					



Automatic Cyclic Pumps PE-30 and PE-32 Series

Read Instructions Before Installing

To Install:

- Obtain all available information from the system designer. This may include bill of materials, lubrication point locations, etc..
- Mount the reservoir in the desired location. It should be:
 - Visible to the operator.
 - Easy to re-fill and service.
- Mounting hole dimensions and clearances are shown on the inside of this instruction sheet.
- Electrical Connections - consult a qualified electrician.
 - Always follow local electrical codes, safety regulations and procedures when installing an electrical system.
 - Wire the pump to the switched side of the machine disconnect so the two are energize simultaneously.
 - Wire per schematic on the inside of this instruction sheet.
- Cycle and interval adjustment
 - Press the up or down arrow keys next to the lube cycle or time interval display for adjustment. Pressing the up arrow key will increase the time. Pressing the down arrow key will decrease the time. When adjusting time values, hold the arrow key in for two seconds. The yellow LED next to lube cycle or time interval will flash depending on arrow key being pressed.
 - When yellow LED light is flashing, press the arrow key to desired setting.
 - After releasing the arrow key, the yellow light will flash for approximately five seconds. During this time the value will be stored into the memory of the computer. Pump will then start lubrication cycle according to time value set.
 - Pressing the "RESTART" key will restart the lube cycle at the beginning of the time value set.
- Pumps equipped with a low level switch. When the switch is activated it will shut down the motor to avoid damage to the pump and activate the alarm.
- General installation practice is to mount the meter units at each lubrication point and interconnect them with tubing. Always point arrow on meter unit in direction of flow. Follow your system schematic. When connecting pipe threads apply a small amount of thread sealant to the external thread. If at all possible, the most distant lubrication point should be piped in an upward position from pump.
- Piping is done with metal or plastic tubing. Take care to prevent dirt or contamination from entering into the piping. You may choose to leave a final fitting (near the meter unit) slightly loose to facilitate the initial bleeding of air and checking of oil delivery to each point. Failure to observe oil at a point requires tracing the system back towards the pump in search of a kink in a line, a loose fitting, or other problems.
- Always use clean oil poured from a clean container. Do not mix oil types or change viscosity without consulting your machine manufacturer.
- Clean the reservoir and filter elements periodically as dictated by the oil cleanliness. If in doubt, check for cleanliness at 3 months, and then 6 months. Determine service frequency based on what is found.
- If contamination enters the system, disconnect lines and flush them out. Empty reservoir, clean filter elements and re-fill the system with clean lubricant.



Automatic Cyclic Pumps PE-30 and PE-32 Series

Read Instructions Before Installing

Wiring:

1. Remove the cover over the display pad (fig. 1). Make sure the pump is facing the same direction as in the illustration.

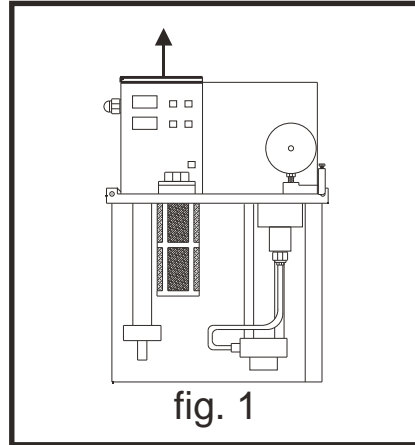

2. Wire per schematic (fig. 2).

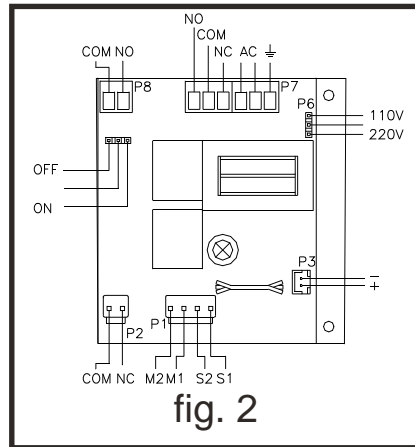

PE-30 Series

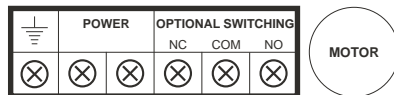

PE-32 Series

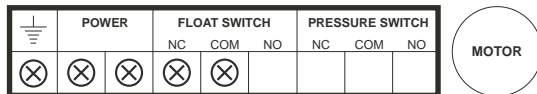

Pressure switch shuts down pump if system pressure drops below set level.



Automatic Cyclic Pumps PE-30 and PE-32 Series

Read Instructions Before Installing

Dimensions: Dimensions in mm

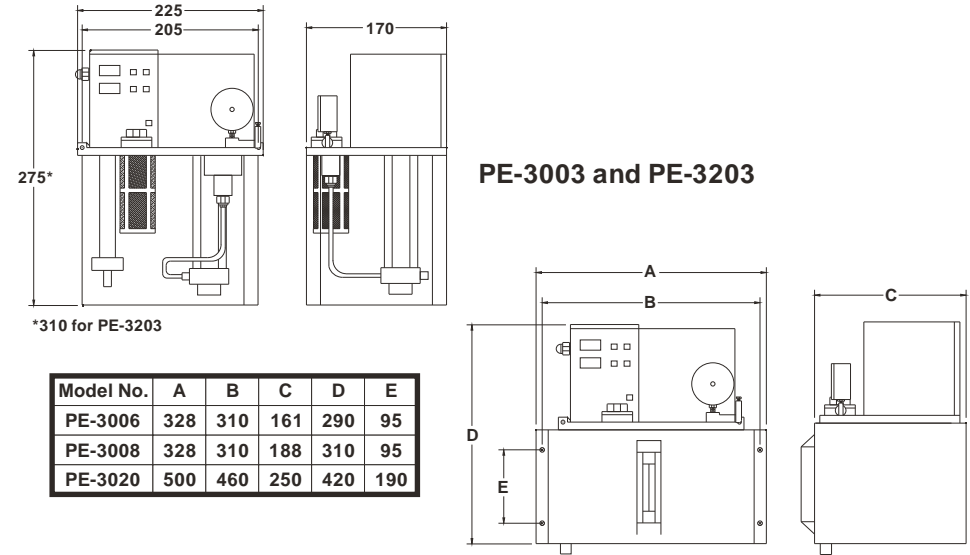

Specifications:

Reservoir Capacity	3 liter plastic 6, 8, and 20 liter steel
Motor Voltage	110v 50/60 standard 220v 50/60 optional
Pump Type	Gear pump
Maximum Pressure	PE-30 100psi PE-32 140psi
Output Connection	5/16-24 (f)