

Best Practices in the Application and Maintenance of Oil Sump Lubrication of Horizontal Process Pumps

*Brad Rake
Vice President of Technology and Market Development
Trico Mfg. Corp.
Pewaukee, Wisconsin*

*Ray Terrell
Technical Support Specialist
Albemarle Corporation
Pasadena, Texas*

NARRATIVE BIOGRAPHY

Brad Rake is the Vice President of Technology and Market Development for Trico Mfg. Corp. In Pewaukee, Wisconsin. He received his degree (Design, 1978) from the University of Kansas, and has been involved in the pump industry for 10 years. Currently serving as the chairman of the Housing Technical Committee for the Hydraulic Institute, and a member of the Pumps and Systems Magazine Advisory Board, he is a recognized author and speaker on the subject of industrial equipment lubrication.

Ray Terrell works at the Albemarle Corporation facility in Pasadena, Texas. He is directly involved in the Technical Support efforts and has been involved in equipment reliability since 1994.

ABSTRACT

Anti friction bearings in process pumps, by design, frequently utilize oil sump lubrication technology. For many years, it was an accepted condition that the lubricating oil used in oil sump bearing lubrication needed to be changed on a regular basis to prevent high levels of contamination that can lead to premature bearing failure, contributing to equipment downtime. Often, the indicators used to determine change intervals were based on visual elements of the oil, such as color. As simple as this method is there are many critical elements that will degrade the overall performance of the lubricant, resulting in premature component failure. Understanding how these elements work together to provide reliable lubrication, and more importantly, increased equipment life and performance are explained. Contained in this document is the compilation of pump manufacturer and component producer design specifications, end user focus group input, new tribology data, laboratory tests, case history studies, and best practice recommendations.

INTRODUCTION

After a review of the field research information, recommendations will be made to pump users which will result in more effective equipment lubrication, increased equipment performance, reduced maintenance costs, and

longer equipment life. This will be accomplished through the proper understanding and application of methods, procedures, and products designed to protect oil sump lubrication. The focus of this paper will be a 3-step approach consisting of prevention, detection, and correction of lubrication related concerns.

OIL SUMP LUBRICATION BASICS

Methods

Although there are many types of lubrication methods to choose from regarding bearing lubrication in horizontal process pumps, the most widely used method is still oil sump lubrication. The most common form of bearing lubrication is direct contact. As the shaft rotates the rolling elements in the bearing, typically steel balls, make contact with a controlled level of oil. Although there is some debate regarding the most effective depth of contact, the amount of contact between the rolling element and the oil is not generally considered a specific measurement. The most important considerations are speed, oil viscosity, and load. It is critical that an effective oil film be maintained between the rolling element and the race of the bearing. Only enough contact between the bearing and the surface of the oil as necessary to "load" the bearing with lubricant is required. If the level of lubricant is too high or too low excessive heat will be generated accelerating the degradation of the oil and shortening the life of the bearing (figure 1). When the level of oil is too high, a condition known as "churning" occurs. Similar to the result of using an egg beater, air is "whipped" into the oil. This, along with the induced heat, increases the oxidation rate shortening the effective life of the oil. When the oil level is too low, there is not sufficient contact to

- Lubricate the bearing, and
- Act as a heat sink to carry away the normal levels of heat generated by the bearing.

Flinger rings and slinger disks are other options with oil sump lubrication. Flinger rings make contact with the oil and provides splash type lubrication, without direct bearing contact (figure 2). If the oil level is too high or too low the flinger ring performance is negatively

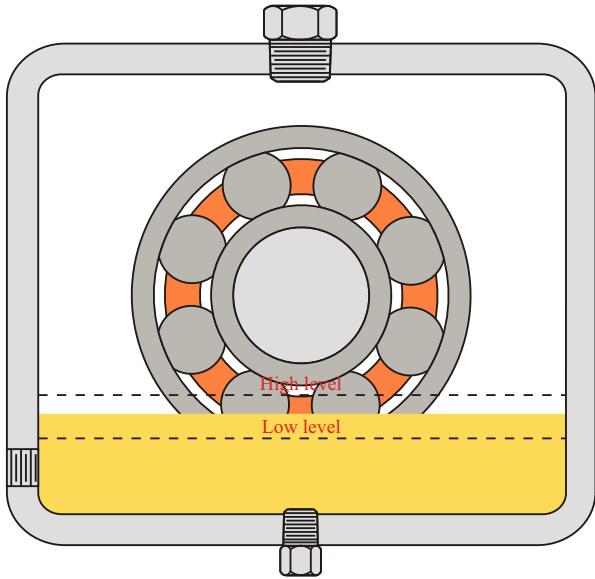

Figure 1. Oil Level Range in Bearing Housing.

affected. If the oil level is too high the ring will become submerged reducing its ability to lift the oil onto the rotating shaft, where centrifugal force directs oil to the bearings. If the level is too low the ring may not be able to pick up enough oil to satisfactorily lubricate the bearings. The other name for this type of lubrication is “Ring Oil” lubrication. The ring oil does not splash the oil to the bearings; it actually lifts the oil from the sump up to the shaft where centrifugal force directs the oil to the rolling element bearings.

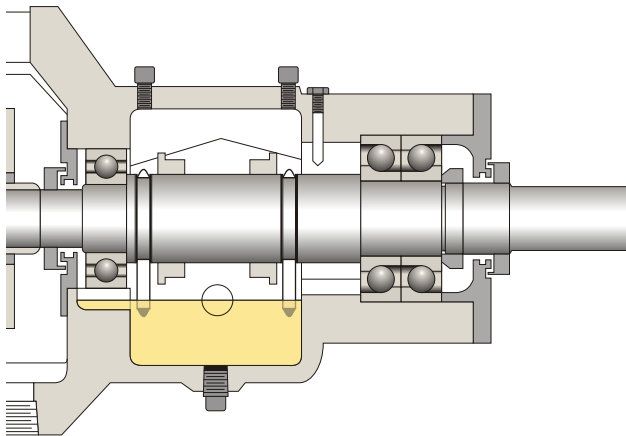

Figure 2. Oil Ring Lubrication.

Slinger disks are attached directly to the shaft and are designed to pick up the oil and splash it throughout the bearing housing. This can be very effective in maintaining lubricant temperature and quantity supplied to the bearing. Depending on the shaft speed and the oil level it can also be a detriment. This type of design has a tendency to increase the amount of entrained air increasing the oxidation rate of the oil if the level is too high. If the level is too low insufficient lubrication to the bearing is possible.

Benefits

Oil sump lubrication is very simple by design. Understanding the basic methods and procedures can result in a very low cost, low maintenance, reliable system of equipment lubrication. Although simple by design, proper application may be more complex. As previously covered, it is important to understand the relationships between oil type, shaft speed, bearing housing design, and oil level maintenance. Once these factors are understood, determining the correct application is relatively easy and consistent.

Application

Perhaps the most widely used method of maintaining the proper level lubricant in a bearing housing is the constant level oiler (figure 3). Simple by design, the constant level oiler replenishes oil lost by leakage through seals, vents, and various connections and plugs in the bearing housing. Once the proper level has been set replacing the oil in the reservoir is the only required maintenance other than the oil changes based on Preventive Maintenance schedules or Predictive Maintenance criteria. View ports can be used to verify proper oil level.

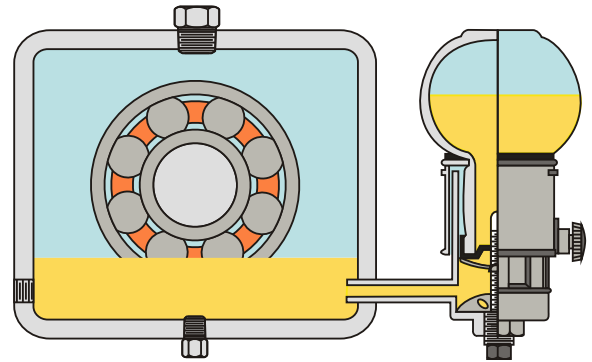

Figure 3. Constant Level Oiler Application.

Critical Elements of Lubrication

The most critical elements of lubrication are quality and quantity. Without one the other is negatively affected. Having the proper quantity of poor quality oil is no better than having an insufficient quantity of high quality oil. Selection of the best oil for the application should also be considered an important factor in optimizing equipment lubrication.

Quality

In basic terms, quality of lubrication can be looked at two ways 1) how the lubricant can become contaminated, and 2) how the lubricant can degrade. Although contamination is widely recognized for its effect on the quality of oil, degradation can be just as damaging to equipment. The leading causes of contamination are particulate, moisture, incompatible fluids, and air entrainment. The leading causes of degradation are oxidation, heat, and use.

Quantity

Having the proper quantity of oil is possibly even more important than maintaining the quality of the oil. Oil sump lubrication does not require that a specific level be maintained for proper "loading" of the bearing. However, if the level of oil in the sump reaches critically low or high points, damaging conditions may occur. In a low level operating condition the bearing will not receive enough lubricant necessary for proper film strength - a precursor to surface contact, skidding, and possible catastrophic failure. In a high level oil operating condition "churning" of the lubricant will occur, accelerating the oxidation rate due to excessive air and elevated temperatures.

FIELD RESEARCH RESULTS

Focus Groups

Reliability and maintenance personnel were invited to participate in focus groups to evaluate best practices of process equipment operation. The input received in these groups was listed and all participants were asked to prioritize the most significant items that they were dealing with in their facility. The overwhelming results pointed to three key factors: people, equipment, and operating environment (figure 4).

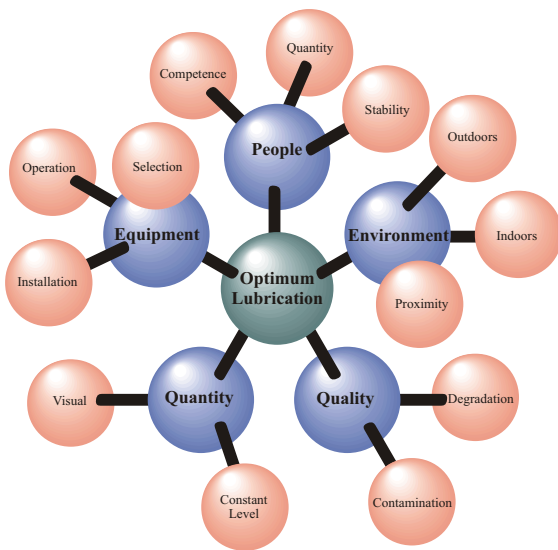

Figure 4. Lubrication Factors.

People

In this subgroup there were three critical areas of consideration: competence, quantity, and stability. Many reliability and maintenance professionals report difficulty selecting the best oil (or grease), lubrication dispensers and systems, and application methods, resulting in an inconsistent approach to proper equipment lubrication. Although simple by design, understanding oil sump lubrication methods and procedures are often the result of "hand me down" information, at times incomplete and frequently wrong. Misuse of oilers, improper filling techniques, and misinterpretation of operating condition all contribute to

inconsistency relative to good maintenance of equipment. Another challenge to proper maintenance regarding personnel is there just isn't enough - people that is. For example, one major facility now has four maintenance people to do the work that just recently was being done by twenty. In some cases the amount of equipment has increased while the number of maintenance people has decreased. This can result in lower quality maintenance methods and procedures. Another great challenge to consistent maintenance is the stability of personnel. Simply put, maintenance of lubrication is often not considered valuable. This can result in less pay, less recognition, and even less budgetary support. The end result - the job nobody wants.

Equipment

The focus group participants recognized three factors essential to reliable equipment operation: proper pump selection, lubrication, and maintenance practices. Not selecting the right pump for the operation is one of the leading causes of premature equipment failure. Often a pump is "over specified" which results in operation outside an acceptable range of the best efficiency point (BEP). The participants felt that pump manufacturers, distributors, and salespeople need to do a better job of helping them understand proper selection.

Improper or ineffective lubrication was widely recognized as an unnecessary cause of premature equipment failure or maintenance. Participants in the group again felt that lubrication manufacturers, dispenser producers, consultants, and salespeople need to help train maintenance personnel in proper practices. Maintenance practices could be improved with more involvement from manufacturers and lubricant producers according to group participants. Too much is left open for interpretation and speculation leading to inconsistency and unnecessary equipment rebuilds. Some suggestions were: training from suppliers and technical consultants, improved technical content on supplier web sites, and better reference material for measuring the effectiveness of the method or product. Many suppliers have support available regarding product and equipment performance via the Internet, customer service professionals, and technical documents. Professional consultants, organizations such as the Hydraulic Institute, and Universities may also provide valuable insight and experience on specific applications

Environment

Again there were three leading items to consider for improved equipment reliability in regard to the operating environment. Indoor and outdoor applications can certainly vary significantly. Temperature ranges, blowing dust and dirt, humidity levels, and weather is much greater in outdoor applications. Maintenance procedures should vary accordingly with special consideration to the spare equipment in the standby

mode. A less obvious factor is the location of the pump with regard to other types of equipment such as fans and blowers. Often these types of equipment can increase contamination ingress along with steam quenching and high-pressure washing. Airflow across pumps generated by fans, blowers, and even the pump motor can be sufficient enough to create a pressure differential between the bearing housing and the surrounding atmosphere. This will increase the ingress rate into the bearing housing, as much as 10 times higher, leading to higher levels of contamination. Steam quenching and high-pressure washing can significantly increase the ingress rate of moisture into to bearing housing. Care should be taken to avoid direct spray or steam around vents, oilers, and seals. Many vents, oilers, and seals are designed to prevent this ingress but need to be specified.

POOR OIL SUMPLUBRICATION-THE CAUSES

Contamination

Particle contamination is possibly the most well known form of lubricant contamination. This form is considered the cause of wear of component parts, silting and surface fatigue. In a study done by the National Research Council of Canada regarding the effects of particle contamination, nearly 85 percent of contaminant wear of components and surfaces were particle induced. To make matters worse, particle contamination can create more particles - more wear. Lower particle counts significantly extend the life expectancy of equipment. Example: By reducing contamination levels from ISO 21/18 to ISO 14/11, life of a 50-gpm pump could be extended by a factor of seven. Particle contamination can occur from ingress from the surroundings, improper cleaning of the bearing housing during maintenance cycles, or corrosion products from the high water content in the oil.

Water contamination of oil can cause several problems relative to oil contamination or degradation. Since each type of oil has its own “safe” level of water before damage can occur, the common practice of measuring parts-per-million (PPM) is not conclusive. There are significant differences between oils, beginning with mineral and synthetic bases. Additive packages, commonly referred to as “ad-pacs”, can also make a difference in how much water an oil can hold before phase separation occurs and free water forms. Temperature also plays a major role in how much water oil can hold. Damaging levels of water, or “free water” begins to occur in some mineral based oils between 400 and 500 ppm at 140 degrees F. Free water may form at 200 ppm at 125 degrees F. in the same oil. Therefore, it is important to know the saturation point of oil at a given temperature to begin to determine a valuable set point for effective lubrication maintenance. By the time water becomes visible, damage is already occurring to both the oil and the surfaces of the equipment and components (figure 5).

Effect		Detection
1300	Extremely damaging to steel element bearings	Visibly cloudy oil
1000		
600	Damaging to bearings	Being sensed at damaging levels. Karl Fischer and centrifugal detection are typically done in laboratories.
200		
100	Very safe, non-damaging	Water sensing detects levels online
	New oil levels	

Figure 5. Moisture in Oil Detection.

Heat - Elevated operating temperatures are a major contributor of oil oxidation. Combined with air, particulate and water contamination, the chain reaction of oil oxidation begins. Additives are affected first, followed by the base stock, which leads to machine and component surface wear and fatigue. For every 10 degrees F oil operating temperature, the oxidation rate doubles. Oil operating at 75° C will last 100 times longer than at 130° C (figure 6).

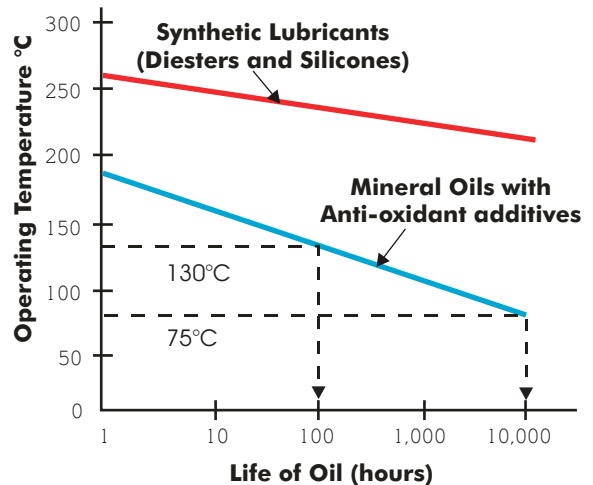

Figure 6. Oil Life Varies with Base Oil Type.

Air Entrainment - Is the primary source of oxygen in the oxidation failure of oil. New oil can contain as much as 10 percent air at atmospheric pressure. Splash lubricated gearboxes, bearing housings utilizing flinger rings or slingers, and compressors are all aeration prone applications. Excessive aeration has a negative effect on acid number (AN), oil color, film strength, and viscosity. In addition, air entrainment can lead to accelerated surface corrosion, higher operating temperatures, and oil varnishing.

Oil Degradation

Primary causes of oil degradation are high heat, air entrainment, and mixing incompatible fluids. Increased viscosity (thickening) is one of the results of this degradation. This usually happens over time, and varies by the combination of these elements (figure 7). Viscosity is the single most important property of a lubricant. In order to more fully understand the

significance of viscosity, it is necessary to understand how a lubricant works. The primary functions of a lubricant are to reduce friction and wear. In order to perform these functions a protective oil film is required. The three basic oil film conditions are referred to as:

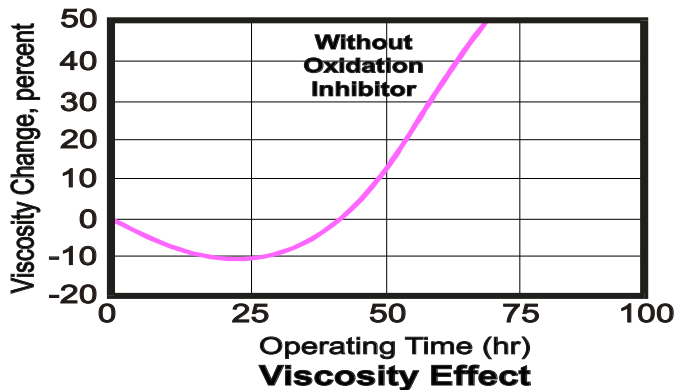

Figure 7. Viscosity Effect as Indicator.

- *Full film* - Denotes the presence of enough lubricant to ensure complete separation of the moving surfaces. Also known as hydrodynamic full film.
- *Elastohydrodynamic (EHD)* - A hydrodynamic film formed by applied pressure or load. Predominantly found in rolling element bearings.
- *Boundary layer* - Sometimes referred to as thin film lubrication and usually the result of insufficient lubricant supply. Although there is lubrication present, there is not enough to prevent metal-to-metal contact.

In rolling element bearings, for instance, the load on a roller causes it to move toward a stationary element, or raceway. This load creates a pressure area that elastically deforms, creating the “Hertzian” contact area. This pressure can go as high as 200,000 PSI compressing the lubricant into a thin film. The viscosity of the oil increases where this fluid film acts as a solid and allows the ball to roll without metal-to-metal contact. When the viscosity is “wrong” the load carrying ability of the lubricant is negatively affected. Additionally, if the oil degrades to a point where it is too thick to penetrate between these surfaces, the oil supply may not be adequate to prevent sacrificial contact.

Oil Starvation

Too little lubricant can be catastrophic. This is commonly the result of incorrect filling, oiler settings, and unrecognized leakage. Without enough oil to prevent friction, “thermal runaway” can happen very quickly to a steel bearing. As the temperature of the bearing increases, the ball and race both expand which creates and even tighter fit. This increases the temperature even more, and this cycle continues to a rapid, catastrophic failure. A less obvious cause of oil starvation is high viscosity - as a result of oxidation or degradation, or

improper oil selection. If the oil is too thick it cannot penetrate the small clearances of a rolling element bearing, particularly at higher speeds.

Excessive Lubrication

It is a common mistake to believe that more is better - especially when it comes to oil sump lubrication. Too much oil can affect the operation of flinger rings, slingers, and direct bearing contact. Churning can lead to higher operating temperature, increased oxidation, and reduced equipment efficiency. Another result of high lubricant levels is leaking seals. Many bearing housing seals are designed for use with proper lubricant levels.

THREE STEP APPROACH TO IMPROVED LUBRICATION

1. Prevention

Of Contamination

Housing components including oilers, seals, and vents, when specified properly can be very effective in preventing contamination (figure 8). For many years constant level oilers have been essential in maintaining oil levels. Most of these were vented to the surrounding atmosphere, which can lead to contamination ingress to the housing sump. By switching to a non-vented oiler

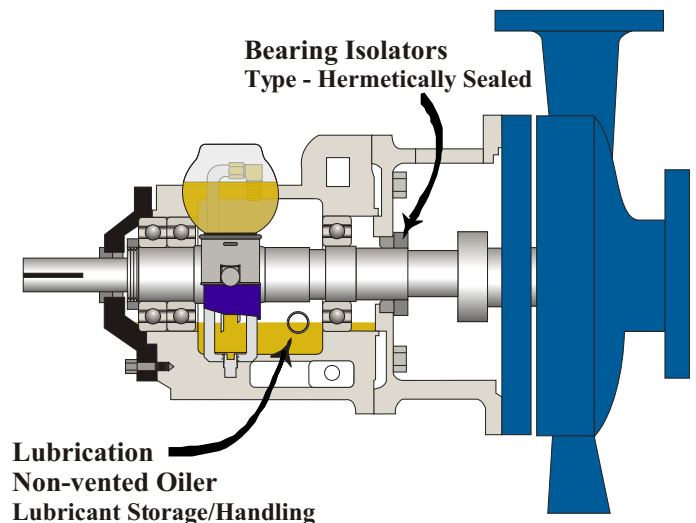

Figure 8. Contamination Ingression Sources

ingression can be significantly reduced. Bearing housing seals, more often recognized as isolators, have been producing positive results in reducing oil leakage and contamination ingress. Labyrinth type isolators are the most widely used on horizontal pumps and are designed to prevent contamination. Designed to allow increased pressure created by normal pump operation to vent through the seal, “laby” seals have proven to be very effective at reducing, and sometimes eliminating, contamination ingress. The rotor and stator are not in contact, which allows for the venting to occur while

preventing wear prolonging the life of the seal. Lip seals can also be very good at preventing contamination, but as a contacting type design require more frequent replacement to ensure close tolerance operation. Since the surfaces of the rotor and stator are in contact, the space between them will increase with time and use and contamination will increase. Lip seals need to be replaced more frequently than do labyrinth or magnetic seals. Magnetic seals have proven to be a good choice for preventing damage to bearings due to contamination. The rotor and stator are designed to be "held together" by an electromagnetic field, which doubles as a barrier to ingress very effective in preventing all types of contamination, including moisture.

Of Degradation

The life of a lubricant is significantly reduced when exposed to high operating temperature conditions. As mentioned previously, the oxidation rate of oil doubles every 18 degrees Fahrenheit. This can be significant when considering pump operating temperatures are frequently near, or above, 140 degrees F. By simply lowering the operating temperature of the oil to 122 degrees F., a 50 percent reduction in the rate of oxidation would be realized doubling the effective life of the oil. The most basic methods to reduce (or maintain) lower oil operating temperatures are:

- Use the correct viscosity oil. Too high OR too low will raise the temperature of the oil.

- Use quality oil. Don't buy cheap oil to save money it will end of costing you more.

- Use the right amount of oil. Maintain proper oil levels too much or not enough will increase the temperature of the oil.

- Keep the oil clean. Contaminated oil operates at a higher temperature than clean oil.

Of Improper Quantity

Understanding and maintaining the proper quantity of lubricant is perhaps the easiest means of increasing lubrication life and effectiveness. Consult with your equipment manufacturer for recommended oil levels, optimum lubricating equipment, and preferred practices. Prevention of excessive oil and starvation operating conditions can be easy and less time consuming with the proper equipment and instruction. A general guideline for most effective oil quantity control is to maintain minimal contact with the lubricating element. Rolling element bearings should not be submerged more than one-half the diameter of the rolling element (ball) at the deepest point of submersion. Flinger rings are more dependant on the shaft speed relative to the depth of submersion, but a good rule-of-thumb to use is to allow full thickness of the ring (for example: 3/16 inch) at the deepest point. Slinger disks are less susceptible to problems of over-lubrication since they are attached directly to the rotating shaft. However, they have been known to cause

misfeeding of constant level oilers through the creation of hydraulic "currents" in the oil sump. Proper selection and mounting often eliminates this condition.

2. Detection

Lubricant Sampling and Testing

Evaluation of lubrication sampling and testing procedures is recommended. Routine oil sampling and changes can be costly and time consuming. Every piece of equipment has its own unique set of circumstances including age, operating environment, process fluid, speed, operating mode, temperature, and history. There are a number of products and recommended practices available to help increase the efficiency of oil sampling, testing, and maintenance. As a general rule, viscosity is the most important lubricant property to monitor. A change in viscosity can be an early indicator of contamination and degradation. Technology is available that will automatically sample and monitor change in the viscosity of oil right at the pump. More commonly, oil is sampled from the pump and sent to an oil analysis lab for evaluation. Test equipment varies from a relatively simple glass viscometer utilizing a capillary tube, to electronic laboratory equipment. By understanding what causes a change in viscosity, many conditions including change in the base number (bn), acid number (an), oxidation, incompatible fluids, and contamination can be identified through additional testing. Know what you're looking for - most lubrication problems are consistent for each piece of equipment.

Visual Indicators

Looking at the oil used in a piece of equipment is not the most reliable method of determining whether contamination is present or the oil has exceeded its useful life. However, there are simple ways to use visual indication as an early warning to degrading conditions. View ports mounted in the housing can be used for both quantity and quality checks. The "business card" analysis tool can also be an easy, low cost method of checking oil quality. In this approach a small amount of oil is placed on the back of a business card, or similar type paper. After a short period of time the way the oil "wicks out" toward the edges of the card can be evaluated in several different ways, such as contamination and degradation. Reference cards are available for visual comparison.

Monitoring Devices

There is a variety of lubrication monitoring devices available, depending on the specific problem. As an example, a widely accepted method of measuring water in oil is to take an oil sample and perform a Karl Fischer titration test at an oil analysis lab. This method is usually considered impractical for the average process pump. Newly introduced on-line monitoring devices (figure 9) measure water contamination by percentage, or Saturated

Relative Humidity (SRH). Continuous monitoring by this type of device prevents unnecessary sampling and oil changes. This measurement is taken below the saturation point of the oil, before phase separation will occur. Just as in the air we breathe, this saturation point varies by temperature hence the “relative” aspect of SRH. How many PPM of water in oil should be considered safe is relative to temperature. For example 500 PPM at 150° F may be safe, or below the saturation point, but the same 500 PPM at 75° F will be above the saturation point phase separation occurs and water condenses at damaging levels. This is very similar to the dew point of the atmosphere when the temperature and dew point converge to within 5°, moisture begins to condense and fog or even rain occurs. New technology “brings automatic understanding” to the safe operating levels of moisture in oil. By maintaining levels of water below the



Figure 9. Moisture Contamination Detection Device.

saturation point, hydrogen embrittlement of steel is prevented, which can eliminate spalling and cracking on the surfaces of steel ball bearings increasing the life of bearings significantly. This level varies from oil to oil in terms of ppm, but is universal in terms of SRH, and can only be measured by sensors specifically designed for this purpose.

3. Correction

Oil Change and Analysis

An evaluation of oil analysis lab results from routine sampling indicates that 25 percent of the samplings are done unnecessarily. Over 60 percent are done after damage is already occurring. This would indicate that over 85 percent of all oil changes and sampling are potentially done at the wrong time. It's important to learn what YOUR problem is in order to know what you're looking for - and when to look for it. For example, if you know your most common problem is water contamination, installation of moisture detection units will eliminate guesswork. If you're not sure what your problem is, monitoring viscosity can be your “first line” of detection and lead to a clearer understanding of the cause through laboratory analysis. Once the specific

cause (or causes) is determined, a monitoring method can be configured for that condition.

Storage and Handling Procedures

It is not uncommon for oil to be stored haphazardly in areas that are not specially designed for lubricant storage. This can lead to contaminated oil and handling tools BEFORE it is even installed in the equipment. It is important to create a controlled atmosphere where temperature and air quality can be controlled. Reduced inventory is recommended - increased inventory turns result in cleaner, higher quality oil. Evaluate how the oil is transported from the storage area to the equipment. Open storage containers and contaminated bottles, funnels, and filling vessels increase the likelihood of filling equipment with contaminated oil. Specially designed containers are available commercially that will decrease the likelihood of introducing contaminated oil significantly (figure 10).



Figure 10. Oil Transfer Equipment.

Maintenance Procedures

Automatic oiler misuse is a leading contributor to improper oil quantity control. Understanding how a constant level oiler works is essential. Two leading causes of misuse are: improper level setting, and "second shift syndrome". Review the instruction sheet provided with the oiler for a better understanding of how to adjust and set the device for proper use. "Second shift syndrome" is a phrase describing how an oil sump becomes over-filled. Maintenance personnel are frequently instructed to keep the constant level oiler reservoir of the oiler completely full. Tests have shown that frequent removal and replacement of the constant level oiler reservoir results in an increased level of oil in the equipment sump (figure 11). Another cause of improper quantity control is pump-filling methods.

Frequently the filler plug on the top of the housing is removed and oil is introduced until the proper level is indicated in the view port. This leads to over-filling since much of the oil is still draining from the shaft, which is in line between the filler port and the sump.

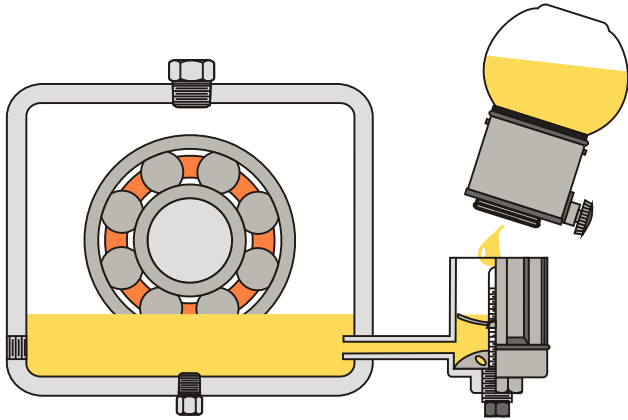

Figure 11. Oiler Feeding During Removal

A general rule to follow is that nothing is routine - identify "special needs" of each piece of equipment. It is extremely important that maintenance and reliability personnel receive adequate training with regards to proper lubrication methods. Request training from equipment suppliers, lubricant suppliers, technical consultants, and respected professionals on the subject. There have been many advances in the lubrication field in the last 10 years if you're still maintaining your equipment the way you did 10 years ago, you could be missing out on many ways to increase equipment reliability and saving money.

Housing Configuration

In a phrase - close it up. Through proper configuration of non-vented oilers, housing seals, expansion chambers, vent replacements, desiccant dryers, and monitoring devices, the pump housing environment can be maintained nearly effortlessly. For example, by installing a "closed system" consisting of a non-vented oiler and a desiccant oil dryer, oil changes were reduced from every 6 weeks to every 3 months. At an estimated cost of \$30 per oil change, the payback on the installation cost of \$72 was realized in less than 8 months (with 2 desiccant cartridge replacements). Additional cost savings may be realized through increased mean time between maintenance (MTBM), and reduced oil disposal costs. Improper configurations of bearing housings are common, and can contribute to high levels of oil contamination. For example, tests have revealed that when a vent is used with certain types of labyrinth seals, the ingress rate of the air surrounding the pump increases as much as 10 times more than without a vent. Contacting shaft seals, such as lip seals and magnetic seals, can greatly minimize ingress. However, pressure may increase without proper configuration of an

expansion chamber. Technical support from the suppliers of these products is essential to insure optimum performance and safe operation.

CASE HISTORIES

Pulp & Paper Plant Wisconsin

One of the leading factors of process pump maintenance costs on pulp and paper plants can be linked to inefficient lubrication. Airborne contamination consisting of humidity and particulate can enter a bearing housing (when a negative pressure variance occurs) through lubricators, bearing isolators, and vents. For many years, it was an accepted condition that the lubrication needed to be changed on a regular basis to prevent high levels of contamination that can lead to premature bearing failure, contributing to equipment downtime. Often, the indicators used to determine change intervals were based on visual elements of the oil, such as color. Too often, this has proven to be *after* damaging levels of contamination already exist. In pulp and paper plants water is a common form of bearing lubricant contamination. Field tests have revealed that by installing closed system lubricators, which are not vented to the surrounding environment, water contamination levels can be reduced by as much as 70 percent, as detailed in this case study, resulting in nondamaging lubrication conditions.

This test was conducted using an ITT Goulds process pump with a two-quart capacity. The pump was also equipped with a non-vented constant level oiler, an expansion chamber, and a desiccant type air dryer. Several other pumps in the immediate area were equipped with vented constant level oilers without the desiccant air dryer.

The prime objective of this test was to qualify the effect of keeping the relative humidity of the air in the bearing housing low in order to lessen the adsorption rate into the oil. This test allows for water ingress through bearing isolators, in the form of humidity, into the bearing housing.

The surrounding atmosphere in the plant was measured at greater than 90 percent relative humidity. A single pump was outfitted with a closed loop constant level lubricator (figure 12). Three other pumps were operated using vented constant level lubricators. Measurements were taken on a monthly basis and the results recorded. After four months, the water content level in the closed system equipped pump reached 265 ppm. The other vented system equipped pumps were measured and all had greater than 600 ppm, and the oil was changed. The closed system equipped pump was then additionally equipped with a desiccant air dryer (figure 13), without changing the contaminated oil. Monthly measurements were again taken, and the results revealed that the water contamination level was never greater than 74 ppm for

eight months. The adsorption rate measured in relative humidity of the oil is shown in figure 14. Comparing the effectiveness of closed system, during the same period of time, the oil in the vented system equipped pumps was changed at least one time, with a maximum of 8 times.

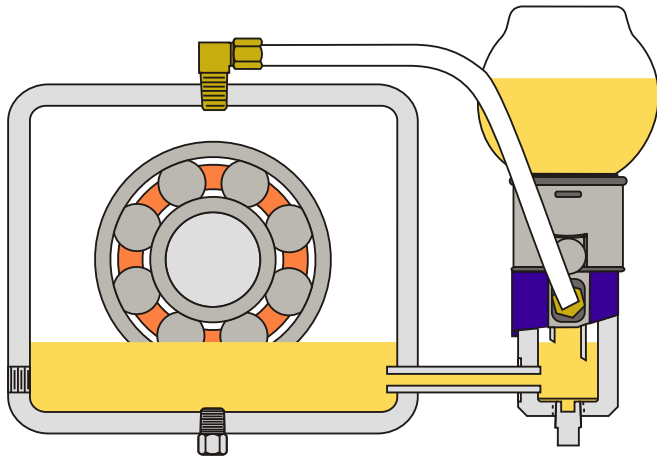

Figure 12. Pressure-Equalizing Constant Level Oiler.

Cost Savings Generated

Typical oil change intervals average three months on pumps equipped with vented lubricators. After installing closed loop lubricators with pressure compensating expansion chambers, and desiccant air dryers, oil change intervals were doubled to an average of six months. In the Menasha test site, using the following list of criteria, this will result in annual savings to \$53,750:

- Increased “up time” - estimated 10 more hours @ \$3000/hour = \$30,000
- Reduce daily inspection time from 2 hours to 1 hour @ \$50/hour = \$13,000/yr
- One half as many oil changes on 150 pumps per year (1/2 hour per change @ \$50/hour) = \$3750/yr
- Reduced liability insurance costs - less potential of oil spill = \$3000 - \$6000/yr
- Reduced disposal costs - currently part of service agreement.

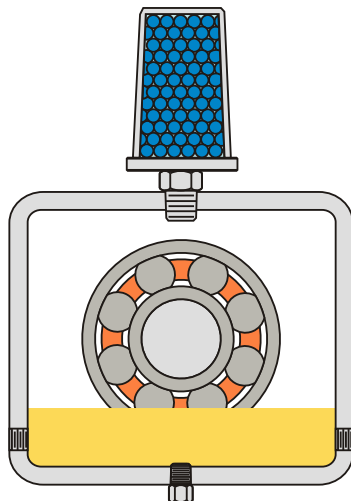

Figure 13. Desiccant Oil Dryer on Bearing Housing.

In this example the pumps were unspared, creating a process downtime condition whenever oil changes were performed. The employee responsible for the daily inspection was “freed up” to do more critical work, and there was no reduction in the workforce. Savings were realized through reduced overtime and reduction in contract labor requirements. Additional cost savings may be realized in the future through lower inventory requirements and increased mean time between failure (MTBF).

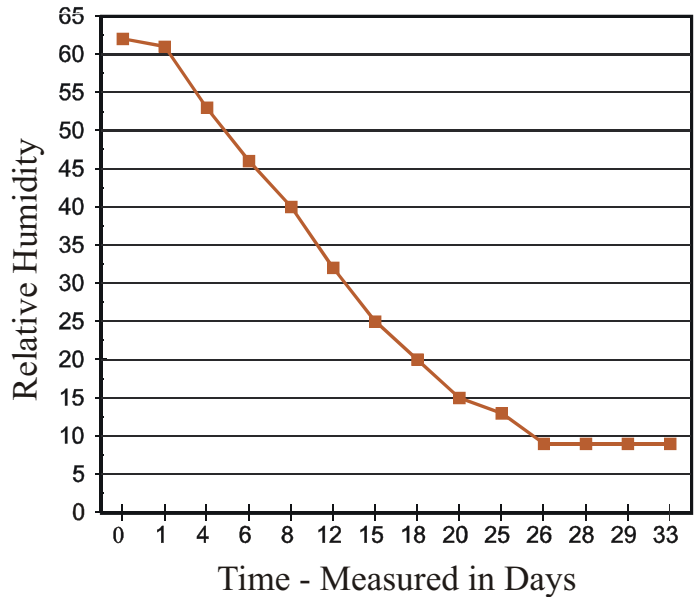

Figure 14. Desiccant Oil Dryer Performance.

Chemical Processing Plant-Texas

A more specific example of increased pump reliability as a result of improved oil sump lubrication resides at the Albemarle chemical processing facility in Pasadena, Texas. Beginning in 1998, a failure history was kept on an ITT Goulds 3196 MT process pump used in the production of Bromide. Operating outdoors, the pump runs 24/7 and was suffering from a very high seal failure rate 11 occurrences per year, at an average rebuild cost of \$3,345. After initial evaluation of the failure mode, most often the mechanical seal, it was determined to be a symptom of other problems. Numerous bearing failures helped direct the attention to the moisture contamination of the oil. In 1999, the first change was implemented, using synthetic oil for the superior demulsification characteristics over the previously used mineral oil. Some improvement was seen, but problems continued. In late 1999, bearing isolators and a sleeveless shaft for more rigidity were installed. Water contamination problems continued until desiccant cartridges were installed. Although the cartridges worked, they last only 2-3 weeks until they became saturated. After installing an automatic moisture removal unit (figure 15) in August of 2000, oil samples showed no contamination. It is now believed that only process problems causing cavitation lead to seal failures, down from 11 per year in 1998 to

five in 2000, and two year-to-date in 2001. At the current rate, this will result in a savings, in rebuild costs alone to just one piece of equipment, of \$23,415 in just one year (2001).



Figure15. Automatic Oil Dryer in Use.

CONCLUSION

Oil sump lubrication is the most widely used and most often misunderstood method of horizontal pump bearing protection. Although other types of lubrication systems are available, oil sump is the most basic type, and the least expensive. Improvements to pump design, seals, monitoring devices, lubricators, and lubricants, all make oil sump lubrication an affordable and effective method of increasing equipment reliability. As described in the case histories of this paper, significant savings can be achieved through reduced maintenance requirements and increased equipment reliability by simply controlling the quality and quantity of the lubrication.

Oversimplification of oil sump lubrication, such as “routine” oil changes can be costly depending on operating configurations and conditions. By understanding the cause of the need for oil changes, proper selection and installation of oil sump lubrication systems can reduce the frequency of oil changes significantly. Associative costs including labor, used oil disposal, laboratory tests, and equipment down time (non-spared) are frequently reduced. For example, in a 200 pump facility where the average frequency of oil change per pump is four times per year (\$30 per change), and the average MTBM is 18 months (at \$3500 per rebuild), the resulting cost for maintenance per pump per year is approximately \$2360. By “closing up” the bearing housing, at a cost of \$120 per year (desiccant cartridge replacement and oiler maintenance) the MTBM is increased to 24 months, and the number of oil changes per year is reduced to two times per year resulting in a cost for maintenance per pump per year of approximately

\$1470 a savings of \$860. This is a payback of over 700% on a relatively small investment of \$120. Lubrication methods and maintenance are often overlooked or misunderstood as a potential for increased equipment reliability and decreased maintenance costs. Don't just change your oil change the way you use it.