



“KG” Gravity Feed Oilers

Read Instructions Before Installing

Installation:

1. Trico “KG” Oilers operate on the gravity feed principle and must be installed above the highest point to be lubricated. “KG” Oilers can be mounted directly into the bearing block.
2. Use hex on sight fitting when installing; never use unusual force or excessive twisting, this may cause damage or leakage.

Caution:

1. Never use type “KG” Oilers where temperatures may exceed 250°F (121°C) continuous or 300°F (149°C) intermittent.
2. Where extreme vibration exists it is advised to remote mount the lubricator on an isolated bracket and connect lubricator to bearing housing using flexible tubing.

Feed Rate Adjustment & Bearing Flushing:

1. Once installed, fill with oil. Feed rate adjustment and shut-off is controlled at the top of the lubricator. With toggle lever in the vertical position, back off adjustment screw until desired drip rate is obtained, then tighten locking ring. To turn lubricator off merely flip toggle lever to horizontal position.
2. When machinery has been standing idle for some time, hold toggle lever at a 45 degree angle for a short time. This will flush bearing and avoid dry startups.

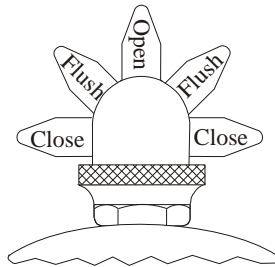

Note:

1. All “KG” Oilers are equipped with dual purpose vented sight chamber. First, if feed rate setting is set too fast, it acts as an overflow; should this situation occur, decrease the feed rate setting slightly. Second, it helps relieve suction or air blocking caused by tight or high speed bearings.
2. To clean lubricator, disassemble and use hot soapy water or kerosene. Never use alcohol, lacquer thinner, or any solvent or cleaner that could attack the gaskets or metal parts. Inspect all parts when reassembling lubricator and replace damaged or worn items.

Trico Mfg. Corp. 1235 Hickory St., Pewaukee, WI 53072

Phone: 262-691-9471 Fax: 262-691-2576 Web Site: www.tricomfg.com

61429 6/99



“KG” Gravity Feed Oilers

Replacement Parts

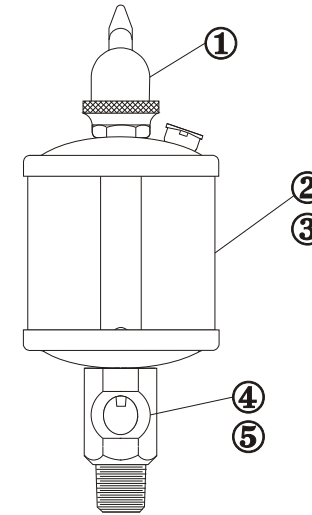

ITEM NO.	PART NO.	DESCRIPTION
1	20077R	1 oz. (30 ml.) Valve Rod Assembly
	20087R	2.5 oz. (74 ml.) Valve Rod Assembly
	20094R	5 oz. (148 ml.) Valve Rod Assembly
	20106R	10 oz. (296 ml.) Valve Rod Assembly
2	20515R	1 oz. (30 ml.) Glass Cylinder & 2 Gaskets
	20516R	2.5 oz. (74 ml.) Glass Cylinder & 2 Gaskets
	20517R	5 oz. (148 ml.) Glass Cylinder & 2 Gaskets
	20518R	10 oz (296 ml.) Glass Cylinder & 2 Gaskets
3	10069R	1 oz. (30 ml.) Cylinder Gasket
	10070R	2.5 oz. (74 ml.) Cylinder Gasket
	10071R	5 oz. (148 ml.) Cylinder Gasket
	10072R	10 oz. (296 ml.) Cylinder Gasket
4	20564R	1/8 Sight Fitting, Glass & 2 Gaskets
	20565R	1/4 Sight Fitting, Glass & 2 Gaskets
	20566R	3/8 Sight Fitting, Glass & 2 Gaskets
5	20567R	Glass Sight & 2 Gaskets
6 not shown	14203	Adapter Fitting 1/8-28 BSPT
	14205	Adapter Fitting 1/4-19 BSPT
	14207	Adapter Fitting 3/8-19 BSPT