

TRICO Watchdog Oil Dryer

Read Instructions Before Installing

Installing 1/2" NPT Oil Dryer:

1. Apply non-volatile pipe thread sealant to 1/2" NPT male thread on adapter.
2. Tighten the adapter with a 7/8" open end wrench on the equipment to be protected
3. Unscrew black cap from the silica gel cartridge.
4. Hand tighten silica gel cartridge to adapter. Do not over tighten.

CAUTION: DO NOT remove the foam diffuser from silica gel cartridge.

Installing Watchdog Oil Dryer With Viewport:

1. Drain oil from wet sump prior to installing the Watchdog Oil Dryer.
2. Apply non-volatile pipe thread sealant to the 1" NPT thread on the main body of the Watchdog Oil Dryer.
3. Hand tighten or use a 1-3/8" open end wrench until one turn from bottoming the hex against the housing wall or until threaded boss is upright (Fig. 1).
4. Verify the centerline of the main body on the Watchdog Oil Dryer (Fig. 2) is parallel with the oil level being maintained.
5. Fill the wet sump through the main body of the Watchdog Oil Dryer until it reaches the recommended range of oil level visible in the sight.
6. Remove black cap from the adapter on the silica gel cartridge. Be careful not to remove 3/4-10 adapter from the silica gel cartridge.
7. Use a 7/8" wrench to tighten silica gel cartridge 1/2 - 3/4 turn on the main body. DO NOT OVER TIGHTEN (Fig. 3).
CAUTION: DO NOT remove the Watchdog Oil Dryer by the silica gel cartridge, use the adapter to remove.

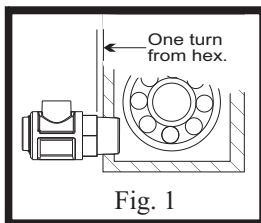

Fig. 1

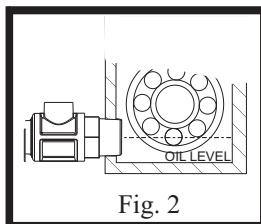

Fig. 2

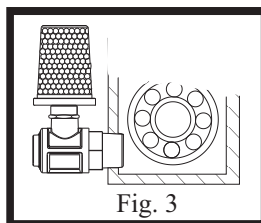

Fig. 3

Maintenance:

After the Watchdog Oil Dryer has been installed, minimal maintenance will be required. The silica gel will turn from orange to dark green during usage. A dark green color indicates saturation and the need to replace the silica gel cartridge. Refer to back side under "Replacement Parts" to order replacement cartridge.

TRICO Watchdog Oil Dryer

Read Instructions Before Installing

- DO remove the silica gel cartridge from the main body during installation and removal. Using the silica gel cartridge as a lever may damage the Watchdog Oil Dryer.
- DO install the Watchdog Oil Dryer with viewport in a 1" factory installed port.
- DO install another cartridge when silica gel is dark green.
- DO use non-volatile, preferably teflon based, pipe thread sealants, and cleaners.
- DO NOT apply chlorinated solvents or sealants. DO NOT use volatile compounds such as acetones.
- DO NOT over torque the Watchdog Oil Dryer during installation. Allow a minimum of one thread between hex and casting wall. Due to material difference less torque is required.
- DO NOT use the Watchdog Oil Dryer for stepping, standing, or heavy loading.

Product Ordering:

DESCRIPTION	CATALOG #
1" NPT with viewport	31807
1/2" NPT without viewport	31808
Metal/Glass Oil Dryer	31848
Metal/Glass Oil Dryer with guard	31849

Replacement Parts:

ITEM #	DESCRIPTION	CATALOG #
1	Silica Gel Cartridge	21841R
2	Main Body	21795
3	Adapter 3/4-10 to 3/4-10	12869
4	Adapter 3/4-10 to 1/2"NPT	12865

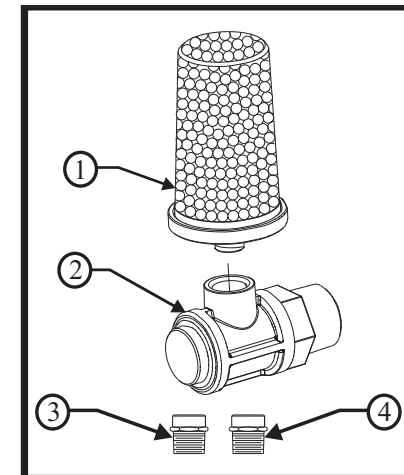

Trico Corp. 1235 Hickory Street, Pewaukee, WI 53072
Phone: (262) 691-9336 Fax: (262) 691-2576 Web: www.tricocorp.com

TRICO Watchdog Oil Dryer

Read Instructions Before Installing

Installing 1/2" NPT Oil Dryer:

1. Apply non-volatile pipe thread sealant to 1/2" NPT male thread on adapter.
2. Tighten the adapter with a 7/8" open end wrench on the equipment to be protected
3. Unscrew black cap from the silica gel cartridge.
4. Hand tighten silica gel cartridge to adapter. Do not over tighten.

CAUTION: DO NOT remove the foam diffuser from silica gel cartridge.

Installing Watchdog Oil Dryer With Viewport:

1. Drain oil from wet sump prior to installing the Watchdog Oil Dryer.
2. Apply non-volatile pipe thread sealant to the 1" NPT thread on the main body of the Watchdog Oil Dryer.
3. Hand tighten or use a 1-3/8" open end wrench until one turn from bottoming the hex against the housing wall or until threaded boss is upright (Fig. 1).
4. Verify the centerline of the main body on the Watchdog Oil Dryer (Fig. 2) is parallel with the oil level being maintained.
5. Fill the wet sump through the main body of the Watchdog Oil Dryer until it reaches the recommended range of oil level visible in the sight.
6. Remove black cap from the adapter on the silica gel cartridge. Be careful not to remove 3/4-10 adapter from the silica gel cartridge.
7. Use a 7/8" wrench to tighten silica gel cartridge 1/2 - 3/4 turn on the main body. DO NOT OVER TIGHTEN (Fig. 3).
CAUTION: DO NOT remove the Watchdog Oil Dryer by the silica gel cartridge, use the adapter to remove.

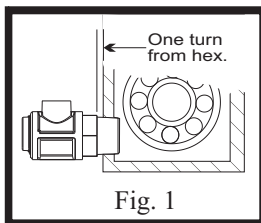

Fig. 1

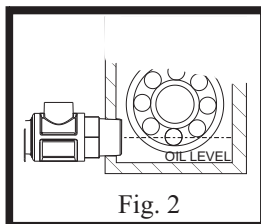

Fig. 2

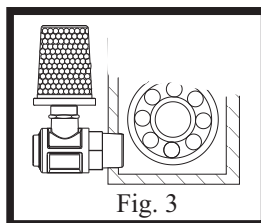

Fig. 3

Maintenance:

After the Watchdog Oil Dryer has been installed, minimal maintenance will be required. The silica gel will turn from orange to dark green during usage. A dark green color indicates saturation and the need to replace the silica gel cartridge. Refer to back side under "Replacement Parts" to order replacement cartridge.

TRICO Watchdog Oil Dryer

Read Instructions Before Installing

- DO remove the silica gel cartridge from the main body during installation and removal. Using the silica gel cartridge as a lever may damage the Watchdog Oil Dryer.
- DO install the Watchdog Oil Dryer with viewport in a 1" factory installed port.
- DO install another cartridge when silica gel is dark green.
- DO use non-volatile, preferably teflon based, pipe thread sealants, and cleaners.
- DO NOT apply chlorinated solvents or sealants. DO NOT use volatile compounds such as acetones.
- DO NOT over torque the Watchdog Oil Dryer during installation. Allow a minimum of one thread between hex and casting wall. Due to material difference less torque is required.
- DO NOT use the Watchdog Oil Dryer for stepping, standing, or heavy loading.

Product Ordering:

DESCRIPTION	CATALOG #
1" NPT with viewport	31807
1/2" NPT without viewport	31808
Metal/Glass Oil Dryer	31848
Metal/Glass Oil Dryer with guard	31849

Replacement Parts:

ITEM #	DESCRIPTION	CATALOG #
1	Silica Gel Cartridge	21841R
2	Main Body	21795
3	Adapter 3/4-10 to 3/4-10	12869
4	Adapter 3/4-10 to 1/2"NPT	12865

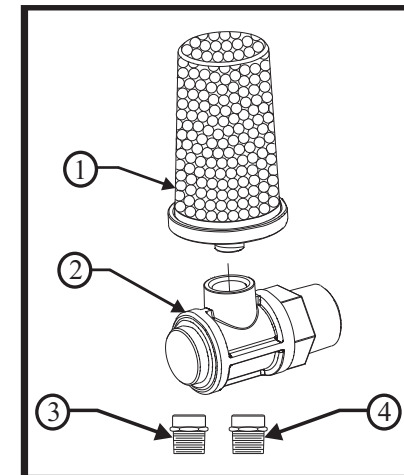

Trico Corp. 1235 Hickory Street, Pewaukee, WI 53072
Phone: (262) 691-9336 Fax: (262) 691-2576 Web: www.tricocorp.com