

DRY WEIGHT: 800 LBS
 SHIPPING SKID SIZE: 41X58
 RACKING CAPACITY: 2500LBS
 MOTOR POWER:
 MAX 100 PSI INLET AIR PRESSURE
 MAX 4 HP @ 3000 RPM VARIABLE
 WETTED PARTS MATERIALS LIST:
 STAINLESS STEEL, GALVANIZED
 STEEL, ZINC PLATED STEEL, PVC,
 VITON, BUNA, BRASS, BRONZE,
 ALUMINUM, GALVANIZED IRON,
 BLACK COATED IRON

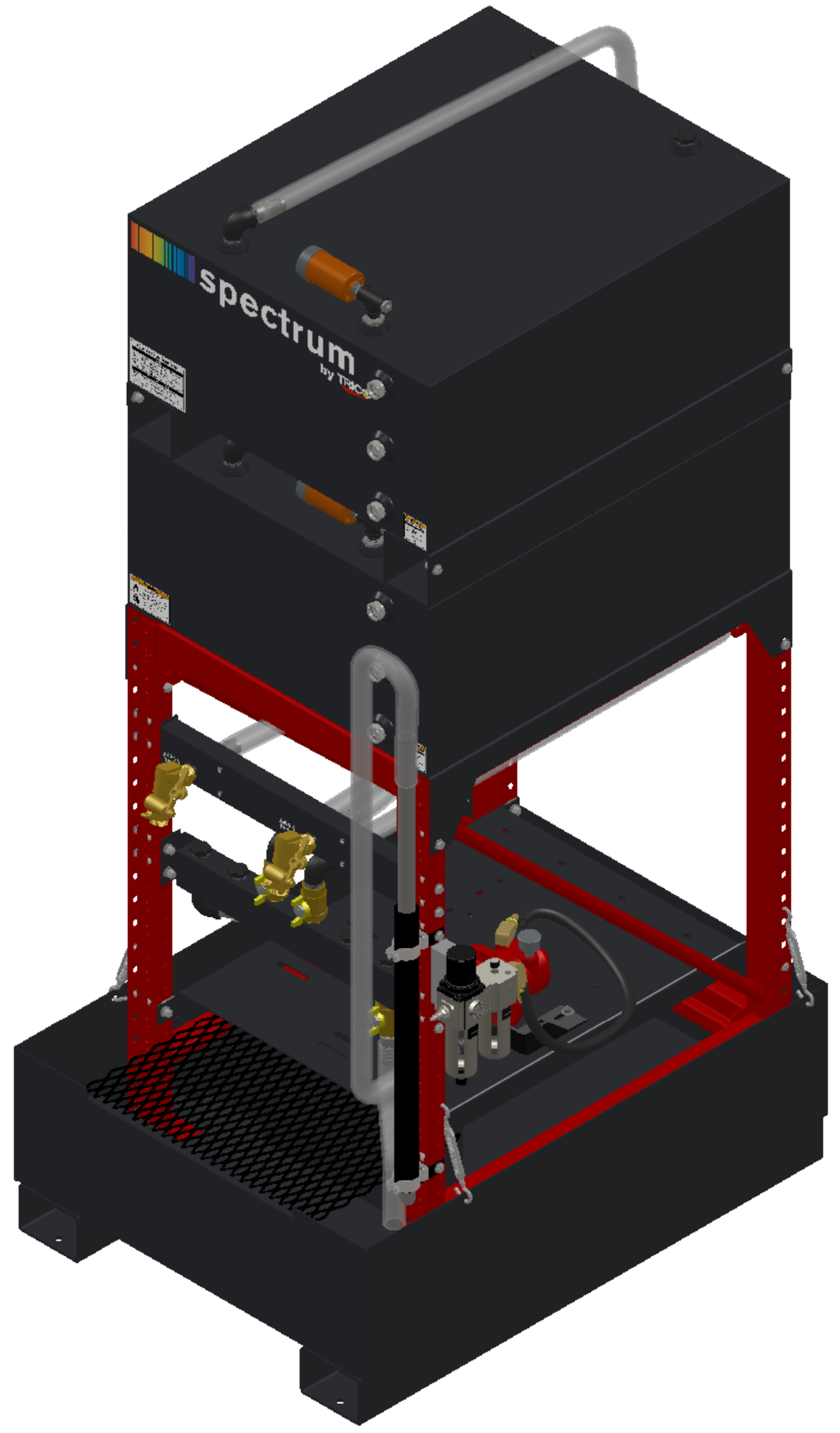

MOUNTING DETAILS

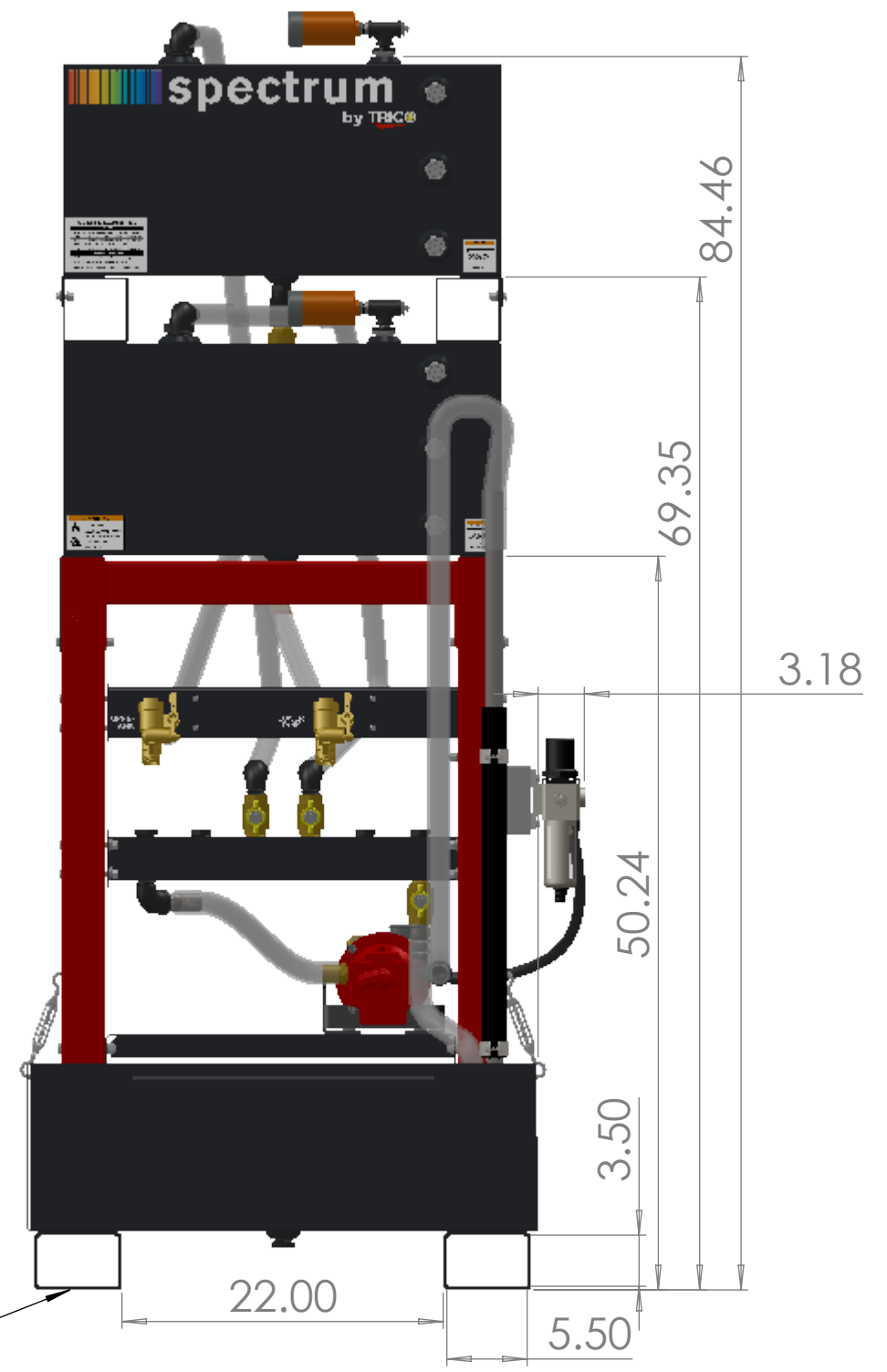
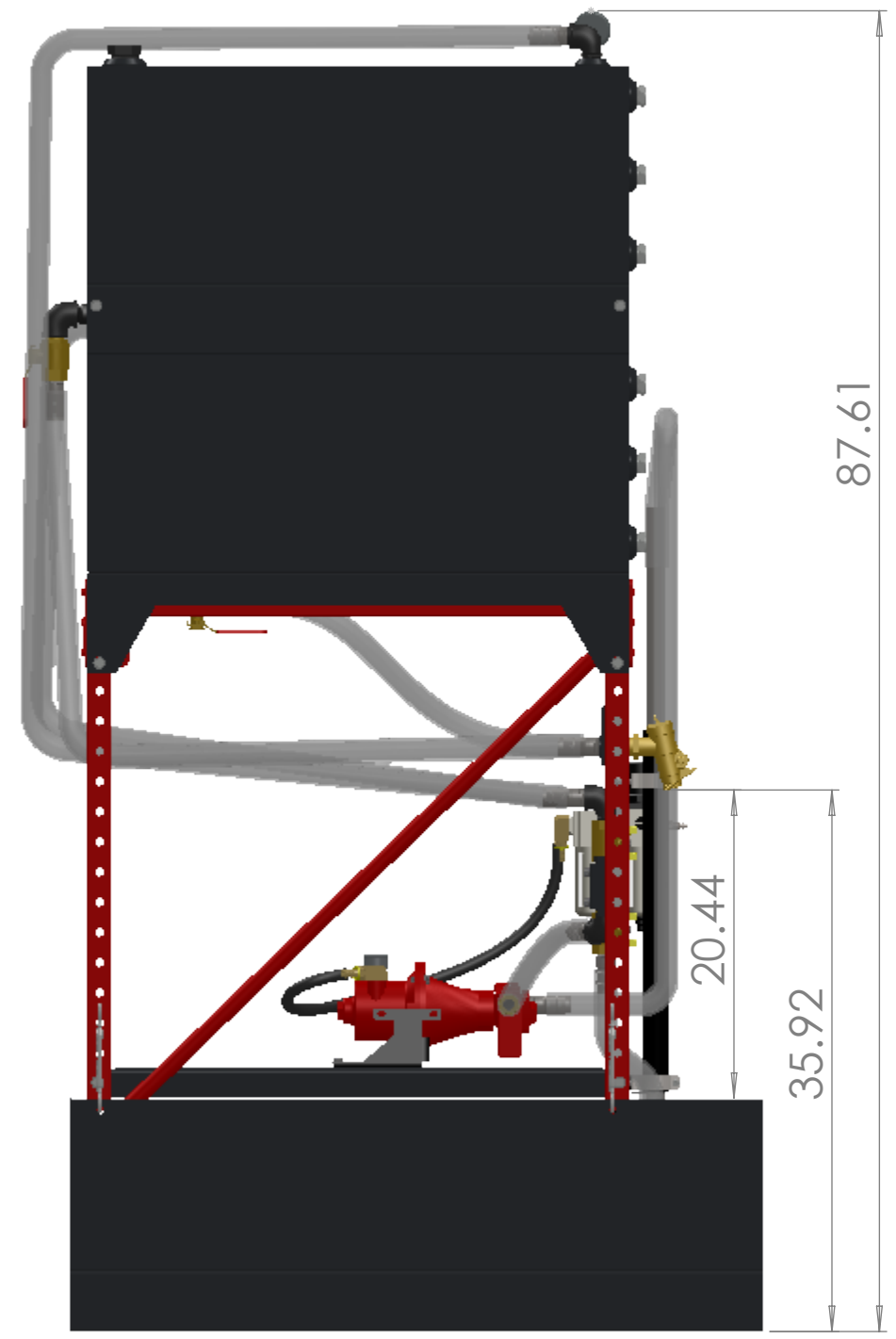
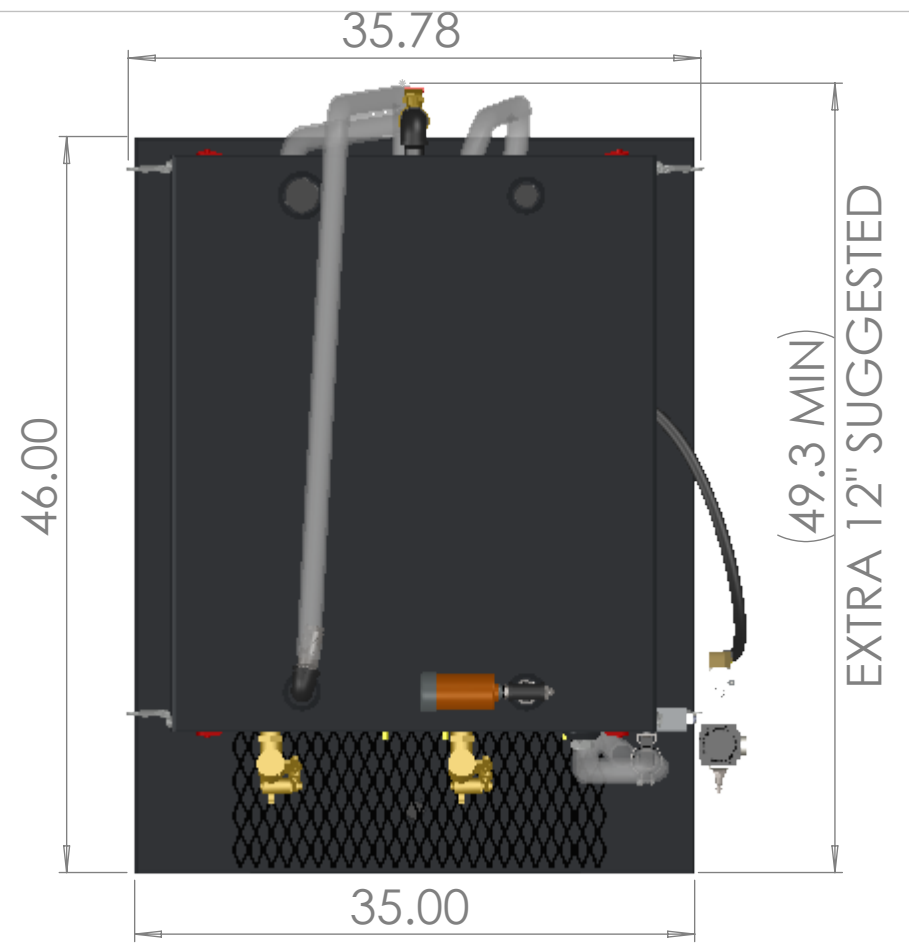
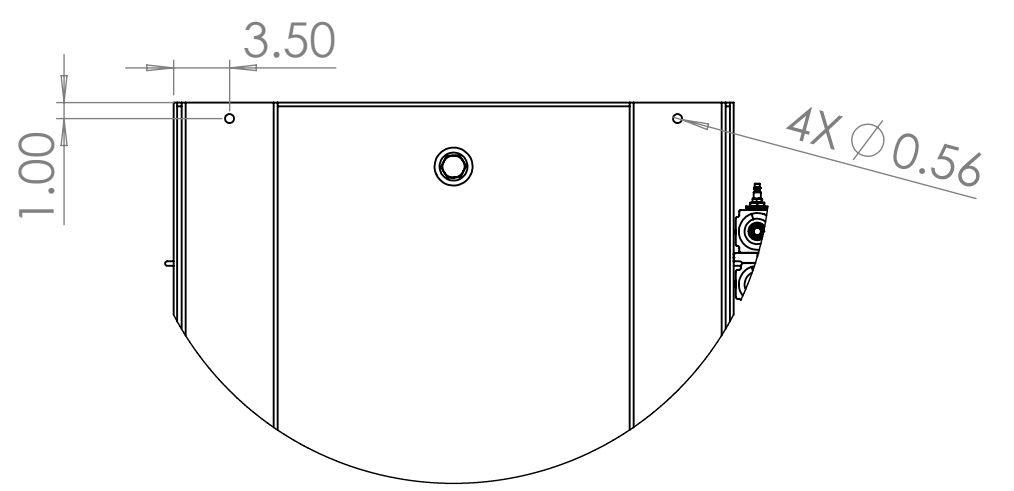

REVISIONS			
REV.	DESCRIPTION	DATE	APPROVED
B	BREATHER UPDATE	2/6/2024	AFB

TRICO

THIRD ANGLE PROJECTION

PROPRIETARY AND CONFIDENTIAL

This drawing and any information or descriptive matter set out hereon are the confidential and copyright property of TRICO and must not be disclosed, loaned, copied or used for manufacturing, tendering or any other purpose without their written permission.

ALL DRAWINGS MUST BE CONSIDERED UNCONTROLLED UNLESS OTHERWISE STAMPED

ALL DIMENSIONS IN INCHES UNLESS OTHERWISE STATED

TOLERANCES:
 X.XX ±.015 ANGLES X±1°
 X.XXX ±.005
 FRACTIONS ±1/16

GEOMETRICALLY TOLERANCED TO ANSI Y14.5 (BS ISO 1101)

NAME: AFB DATE: 2/14/2022

DRAWN: AFB

CHECKED:

APPRVD:

DESCRIPTION / TITLE:
PNEUMATIC ESSENTIAL 2 TANK SPECIFICATIONS

SIZE: C PART NUMBER: **37245** REV. B

MATERIAL:
 STOCK SIZE:
 FINISH:
 SCALE: 1:10 SHEET: 1 OF 1

DO NOT SCALE DRAWING